

# TOSUN





•

•

•

•

•



- 
- 
- 
- 
- 
- 
-

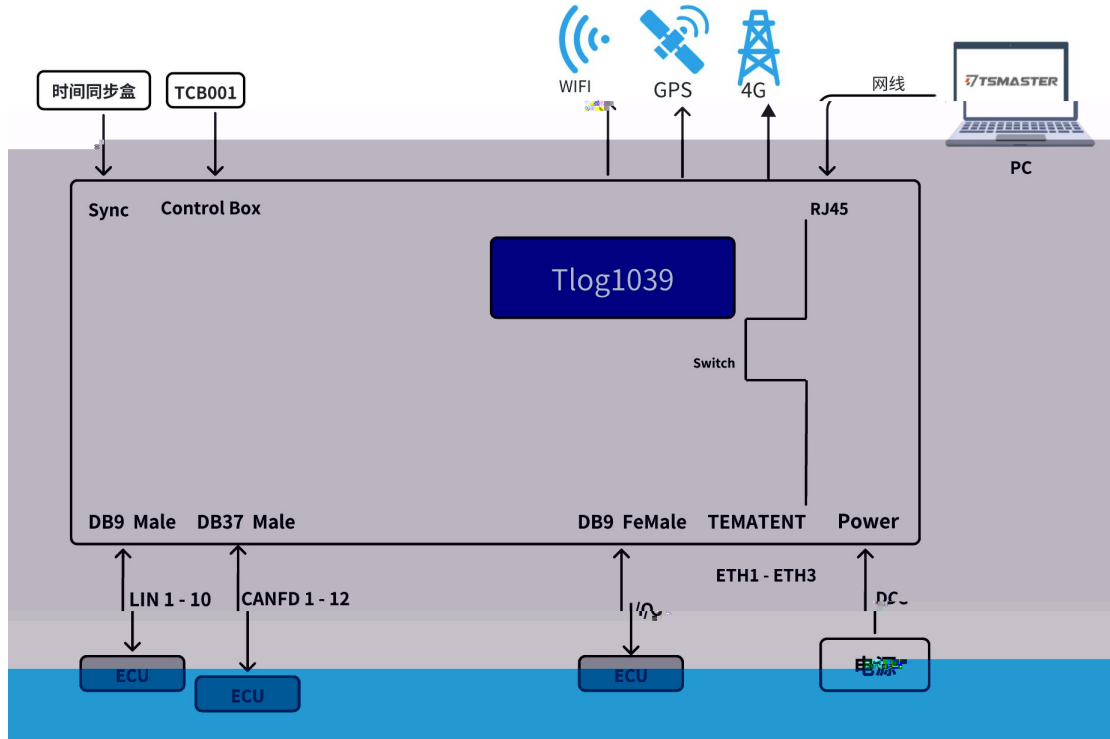





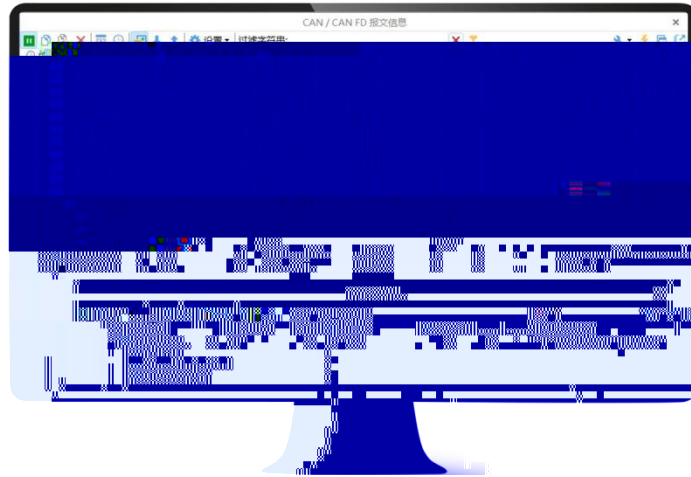

•

•

•

•

•



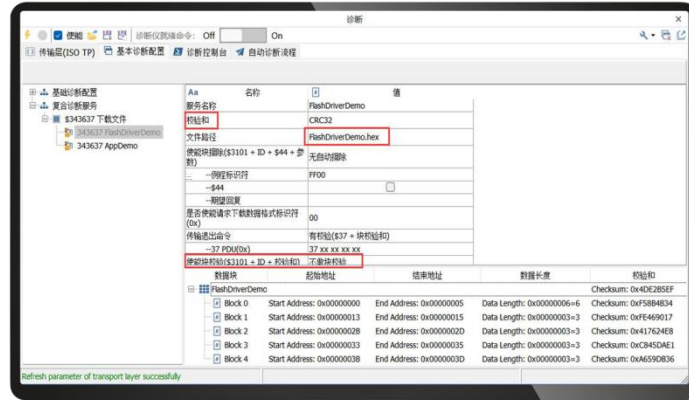

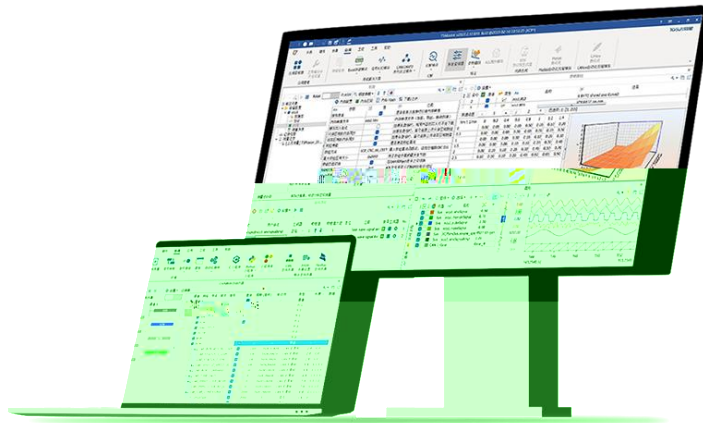

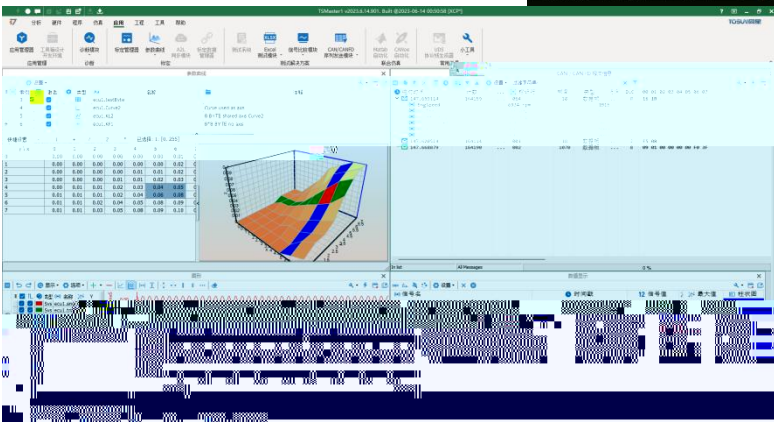
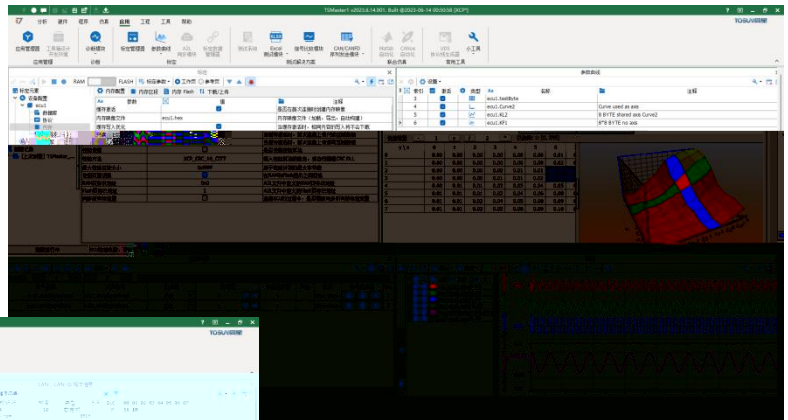





✓

✓

✓

✓

✓

✓

✓

✓

✓

✓

✓

✓

×





|  |  |  |  |  |  |  |
|--|--|--|--|--|--|--|
|  |  |  |  |  |  |  |
|  |  |  |  |  |  |  |

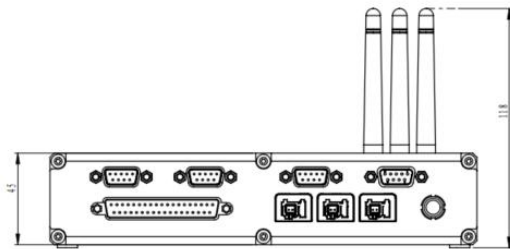
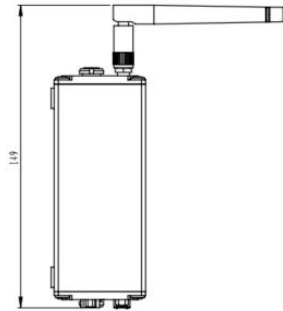
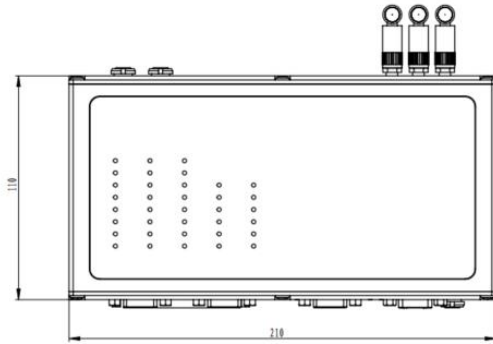

✓



✓



✓



✓



✓



✓



✓



✓

**2.4G小折叠 增益3DBI**

- 频段: 2400-2500mhz
- 总长: 11cm
- 折叠长: 9cm

折叠长9cm  
2cm

SMA内针 SMA内孔

**2.4G 5G 5.8G双频胶棒天线 wifi蓝牙天线Zigbee外置小辣椒天线SMA**

蓝牙耳机壳 蓝牙耳机天线 蓝牙耳机壳 蓝牙耳机壳

**¥1.9** - 已售 20万+

品牌: 40个品牌可选, 预计明天送达 快速1.00 广东深圳 至 上海 嘉定

保修: 7天无理由退货 极速退款

可选交付: 货到付款支付

颜色分类: 2.4G白色直插 2.4G黑色直插 2.4G-总长3.5CM直插

2.4G-总长3.5CM弯头 2.4G-总长5CM直插 2.4G-总长5CM弯头

2.4G-小辣椒直插 2.4G-小辣椒弯头 2.4G-全铜直插5.2CM

2.4G直插7.2cm 2.4G弯头7.2 2.4G内六角 2.4G白色直插小折叠

**2.4G-黑色直插小折叠** 2.4G-总长10CM直插 2.4G-总长10CM弯头

2.4G-直插 2.4G白色直插大折插 2.4G-黑色直插大折插 双磁贴架白色

双磁贴架黑色 双磁小折插黑色 双磁大折插黑色 双磁刀架19.5CM黑色

规格:  内孔

✓

✓

✓

✓



✓

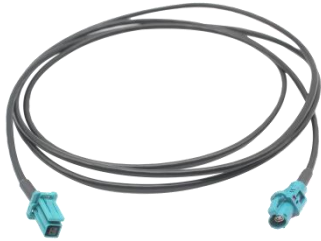

✓

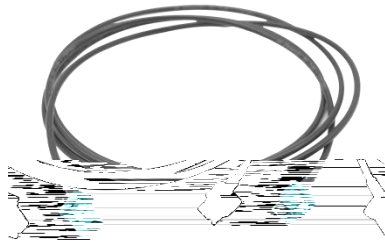

✓











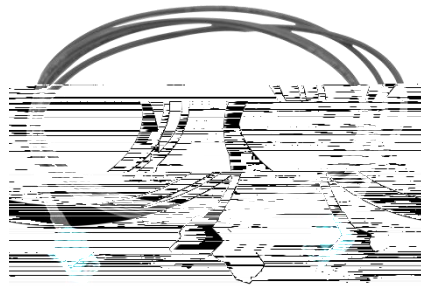

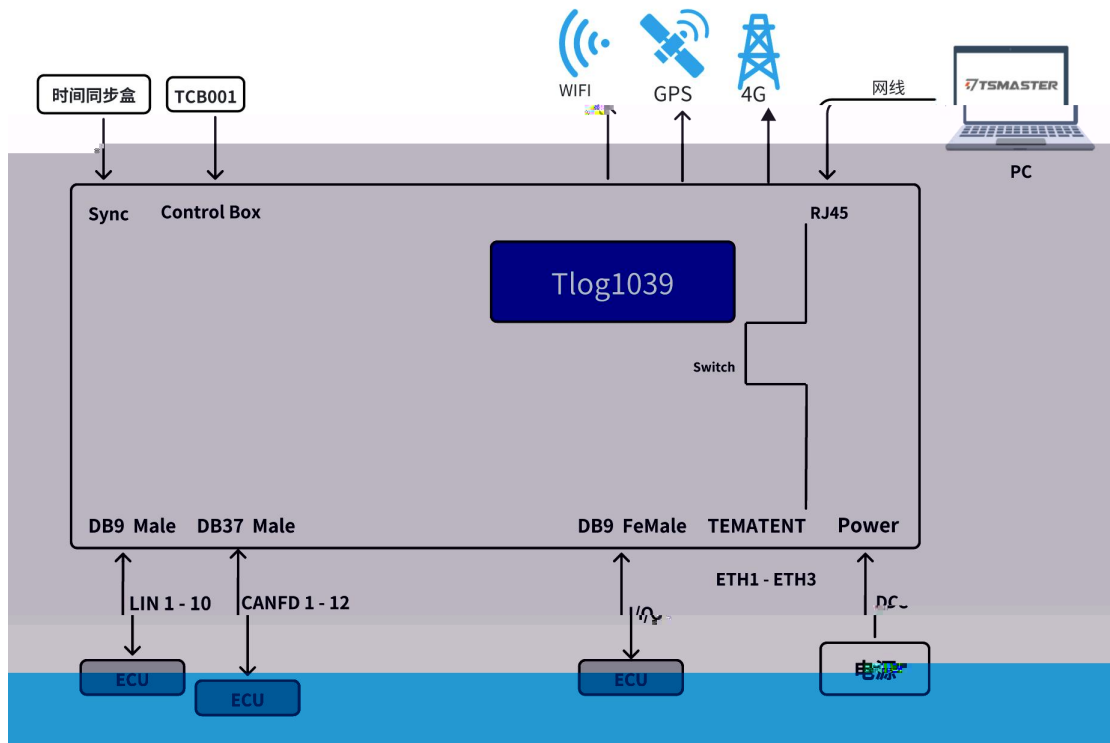

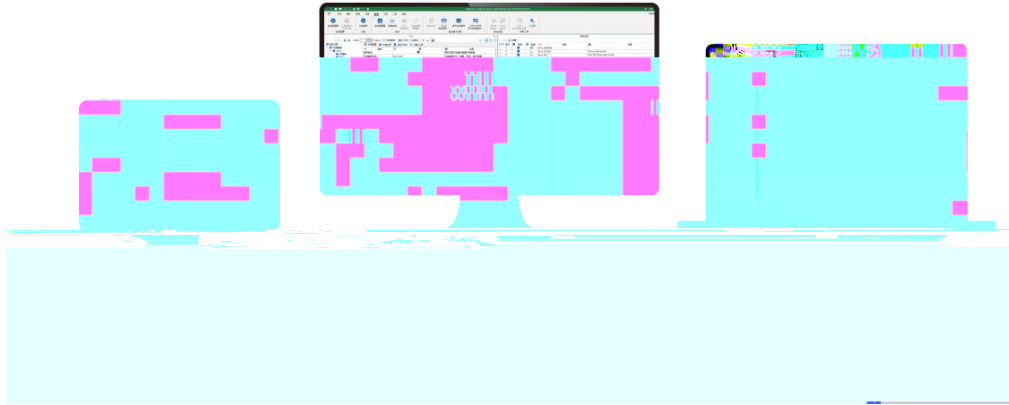



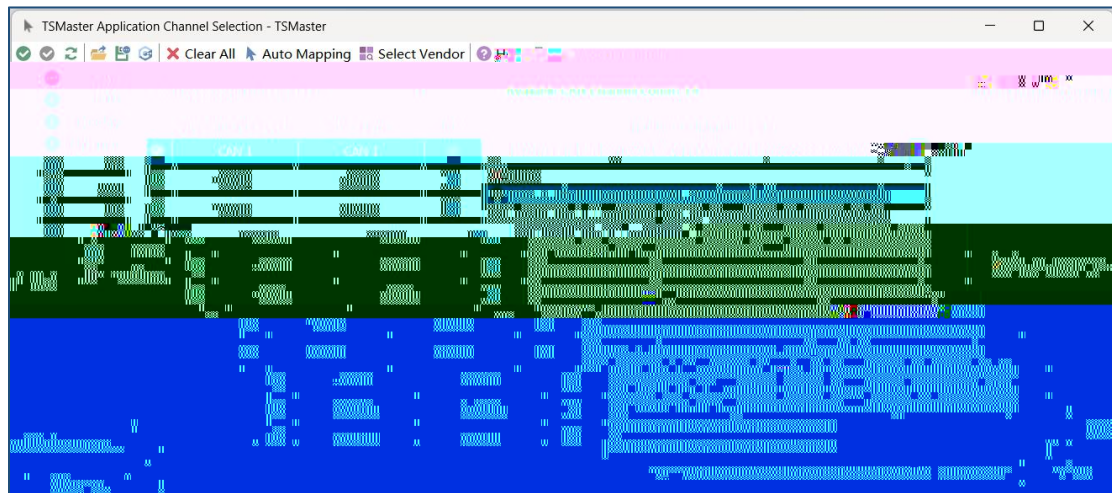
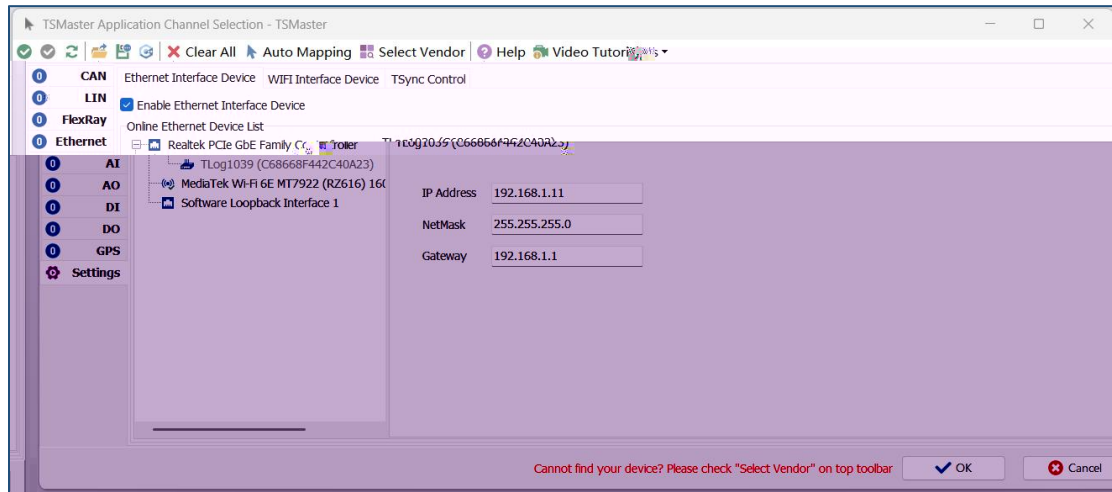

Hardware Configuration

2025.10.23.1639

TSMaster CAN FD Channel 1 - TOSUN Eth IF TLog1039 1 CAN FD Channel 1

Default Apply

| Parameter                          | Value                               |
|------------------------------------|-------------------------------------|
| CAN Controller Type                | ISO CAN FD                          |
| Arbitration Phase Baud-rate [Kbps] | 500                                 |
| Data Phase Baud-rate [Kbps]        | 2000                                |
| Arbitration Phase Bit Timing       | TSEG1=63,TSEG2=16                   |
| Data Phase Bit Timing              | TSEG1=15,TSEG2=4                    |
| Arbitration Phase SJW              | 15                                  |
| Data Phase SJW                     | 3                                   |
| Controller Mode                    | Normal                              |
| Filter Type                        | Allow All                           |
| Filter ID                          | XXXXXXXXXX                          |
| Auto Recover From Busoff           | <input checked="" type="checkbox"/> |
| Termination Resistor               | <input checked="" type="checkbox"/> |

|  |  |   |  |
|--|--|---|--|
|  |  |   |  |
|  |  |   |  |
|  |  |   |  |
|  |  | - |  |
|  |  |   |  |
|  |  |   |  |
|  |  |   |  |
|  |  |   |  |

|  |  |  |  |
|--|--|--|--|
|  |  |  |  |
|  |  |  |  |
|  |  |  |  |
|  |  |  |  |

•

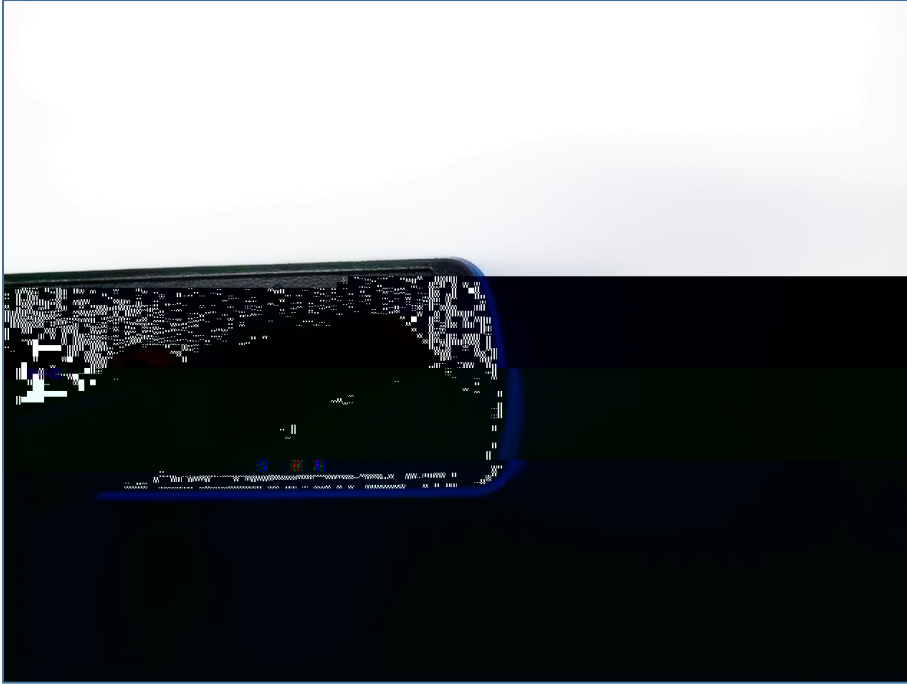

•

