

# User Manual



, Q&A



---



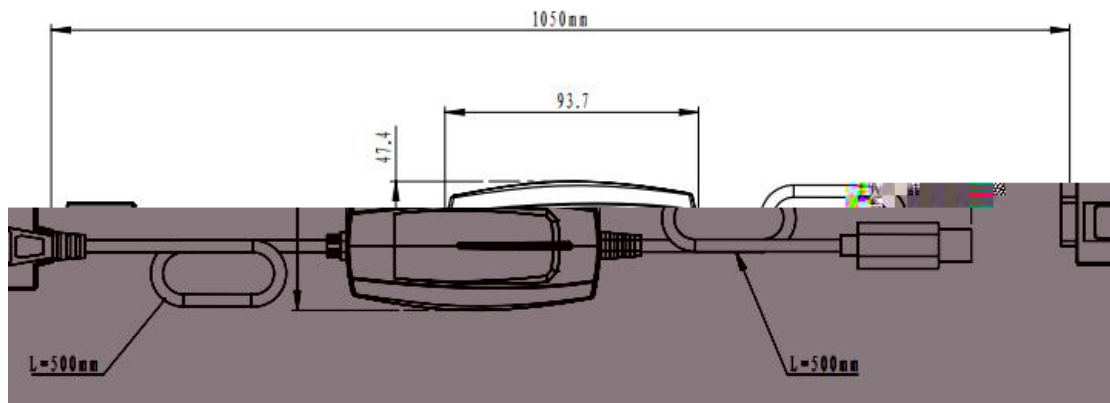

--	--	--	--	--	--







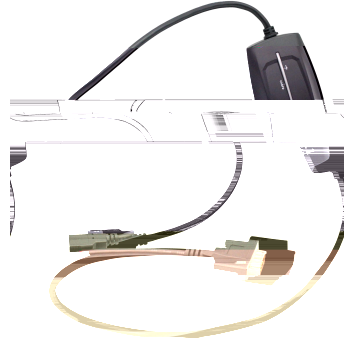



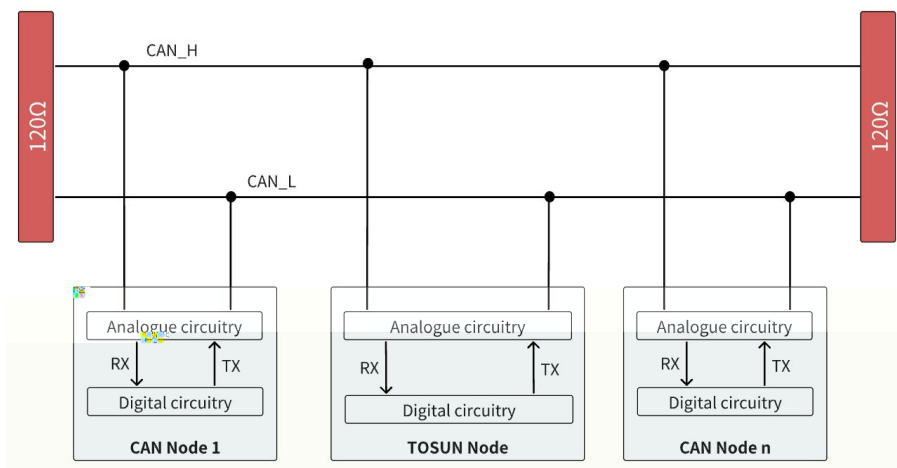
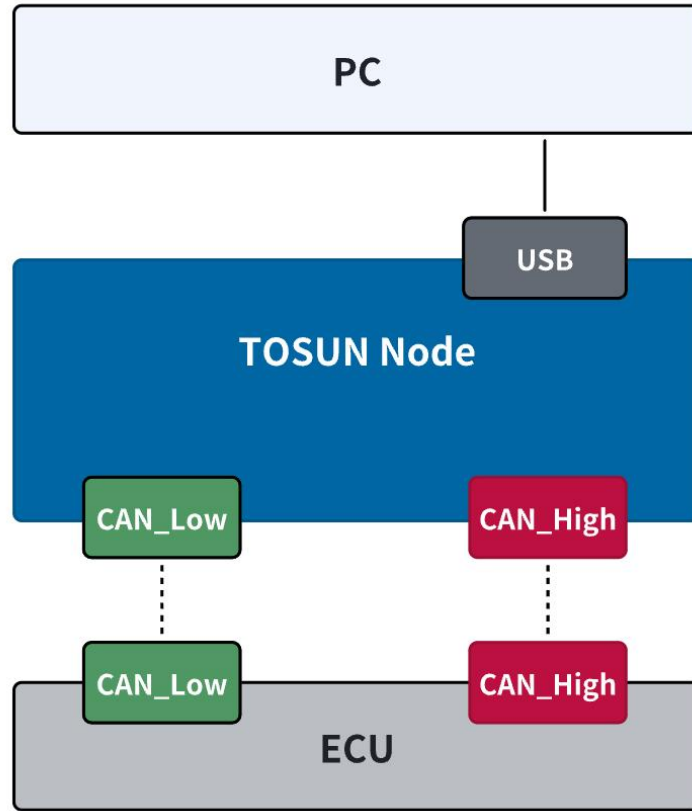

```
tosun@tosun-HP-ProBook-455-15-6-inch-G9-Notebook-PC:~/Desktop/TC111/TC111/00_user$ ls
socket_can.c  socket_drv.c  TOSUN-SOCKET_CAN使用指南 v1.0.0.docx  TOSUN-TC111用户手册 v1.0.0.docx
tosun@tosun-HP-ProBook-455-15-6-inch-G9-Notebook-PC:~/Desktop/TC111/TC111/00_user$
```

```
tosun@tosun-HP-ProBook-455-15-6-inch-G9-Notebook-PC:~/Desktop/TC111/TC111/00_user/socket_drv$ make
-e -----
-e ● Checking build environment...
-e -----
# make
# sudo
# kernel build dir
# 必要头文件
# 必要源文件
-e ☑ Using gcc-12, version 12
-p ↘ Building kernel module 'toss_socket' for 6.9.0-generic...
```

```
tosun@tosun-HP-ProBook-455-15-6-inch-G9-Notebook-PC:~/Desktop/TC111/TC111/00_user/socket_drv$ make install
-e Installing kernel
  Installed. Load with: sudo modprobe tosun_socket_can
tosun@tosun-HP-ProBook-455-15-6-inch-G9-Notebook-PC:~/Desktop/TC111/TC111/00_user/socket_drv
```

```
[389E:1001,0049/input/input93]
[389E:1001,0049] tosun_socket_can 0003:389E:1001,0049: input,hidraw0: USB HID v1.11 Gamepad [TOSUN TOSUN HS CANFD1,SOCKETCAN,TC111] on usb-0000:04:00,3-2/input0
[389E:1001,0049] Report Type: Input, ID: 0xa5, Size: 32760 bits
[389E:1001,0049] Report Type: Output, ID: 0xa5, Size: 32760 bits
[389E:1001,0049] list empty
[389E:1001,0049] serial number is d47d165671eec4e3
[389E:1001,0049] tosun_usb TOSUN_USB_CANUSB
[389E:1001,0049] tosun_socket_can 0003:389E:1001,0049 can0: device can0 registered
```

```
tosun@tosun-HP-ProBook-455-15-6-inch-G9-Notebook-PC:~/Desktop/TC111/TC111/00_user/socket_drv$ ln -s /dev/net/tun /dev/net/can
1: veth: <BROADCAST,MULTICAST,UP,LOWER_UP> mtu 65536 qdisc noqueue state UNKNOWN mode DEFAULT group default qlen 1000
    link/loopback 00:00:00:00:00:00 brd 00:00:00:00:00:00
2: enp1s0: <BROADCAST,MULTICAST,UP,LOWER_UP> mtu 1500 qdisc fq_codel state UP mode DEFAULT group default qlen 1000
    link/ether 7c:57:58:19:12:f9 brd ff:ff:ff:ff:ff:ff
3: wlan2s0: <BROADCAST,MULTICAST,UP,LOWER_UP> mtu 1500 qdisc fq_codel state UP mode DEFAULT group default qlen 1000
    link/ether 7c:57:58:19:12:f9 brd ff:ff:ff:ff:ff:ff
```







--	--	--	--





## Software

- Support CAN(FD)/LIN/FlexRay/SOME/IP/RS485
- USB/ethernet/RS485/RS422/RS485/RS422/RS485
- Embedded code generation/Application builder
- Encrypt/decrypt/encrypt/decrypt

www.tosja.com

### Company

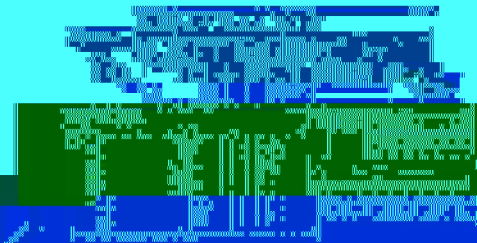
www.tosja.com



## Hardware

- 1/2/4/8-channel CAN FD to USB/PCIe device
- 1/2/8-channel LIN to USB/PCIe device
- Multi channel FlexRay/CAN FD to USB/PCIe device
- Multi channel CAN FD to USB/PCIe device

www.tosja.com

### Multi channel CAN FD to USB/PCIe device

#### Key features

- Multi channel CAN FD to USB/PCIe device
- Multi channel CAN FD to USB/PCIe device
- Multi channel CAN FD to USB/PCIe device



## About TOSJA

### Services

- Multi channel CAN FD to USB/PCIe device
- Multi channel CAN FD to USB/PCIe device
- Multi channel CAN FD to USB/PCIe device
- Multi channel CAN FD to USB/PCIe device
- Multi channel CAN FD to USB/PCIe device
- Multi channel CAN FD to USB/PCIe device

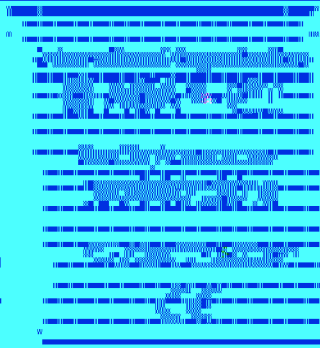
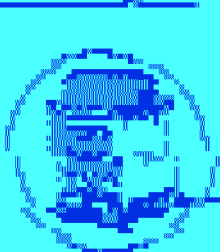
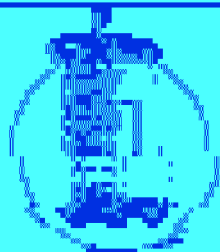
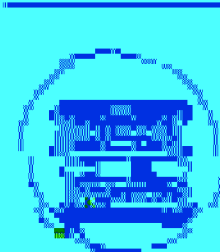

www.tosja.com

