



"

"



ž



B* D

			±	
			±	
			±	

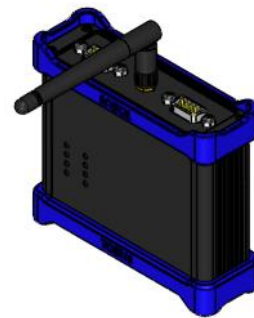
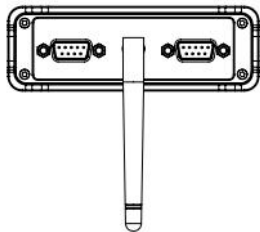
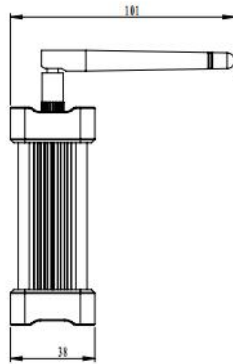
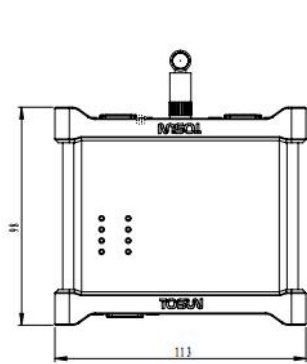

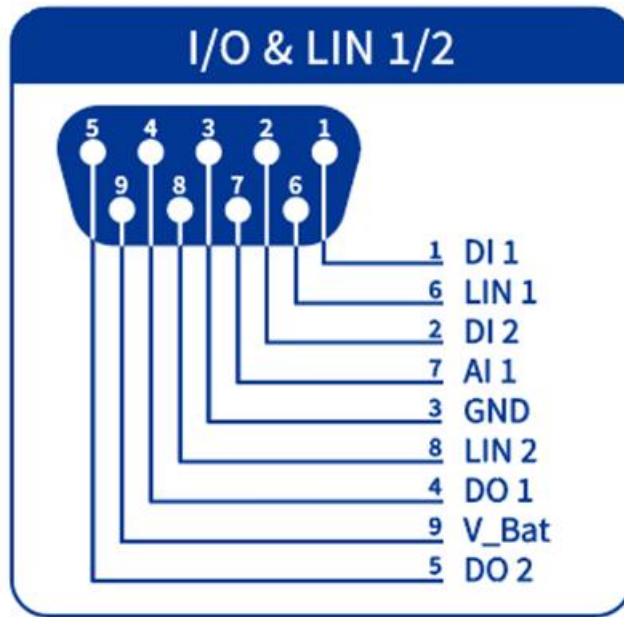
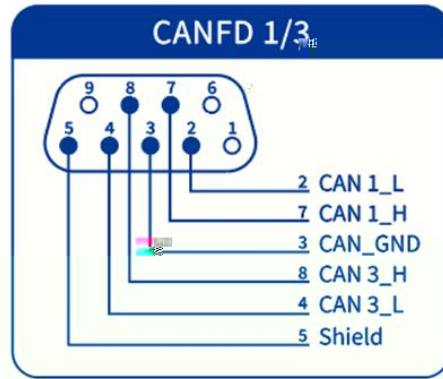
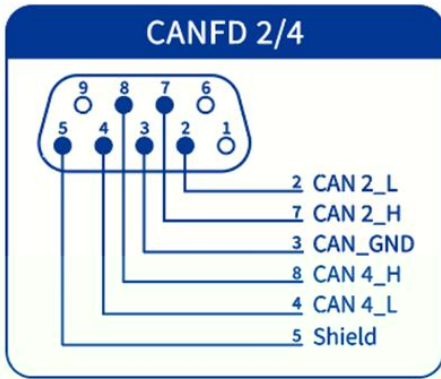

CANFD 1/3
CANFD 2/4

Tlog1004







- CANFD 1 ● LIN 1
- CANFD 2 ● LIN 2
- CANFD 3 ● GPS
- CANFD 4 ● Log



CANFD/LIN/GPS Data Logger

I/O & LIN 1/2
Host

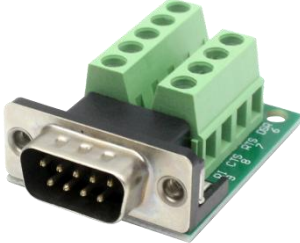
⊕ ⊖
DC9-36V GND



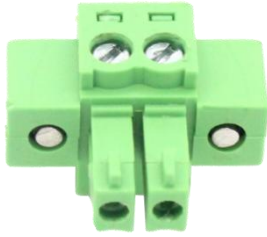

硬件配置

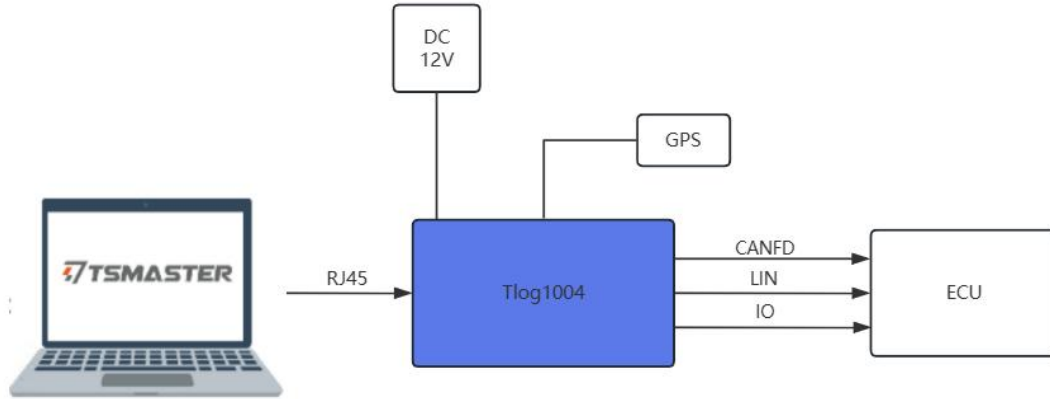
2025.3.12.16:38

应用程序通道

总线通道配置

CAN 1

CAN 2

CAN 3

CAN 4

LIN 1

LIN 2

Master CAN FD 通道 1

TOSUN USB TC1016 1 CAN FD 通道 1

默认

应用

参数	值
CAN控制器类型	ISO CAN FD
仲裁 (kbauds)	500
数据段波特率 (Kbps)	8000
仲裁段位时间	TSEG1=63,TSEG2=16
数据段位时间	TSEG1=2,TSEG2=2
仲裁段同步跳变宽度	15
数据段同步跳变宽度	1
控制器模式	正常模式
接收类型	接收所有
过滤 Id	XXXXXXXXXXXX
自动从Busoff状态中恢复	<input checked="" type="checkbox"/>
终端电阻激活	<input checked="" type="checkbox"/>

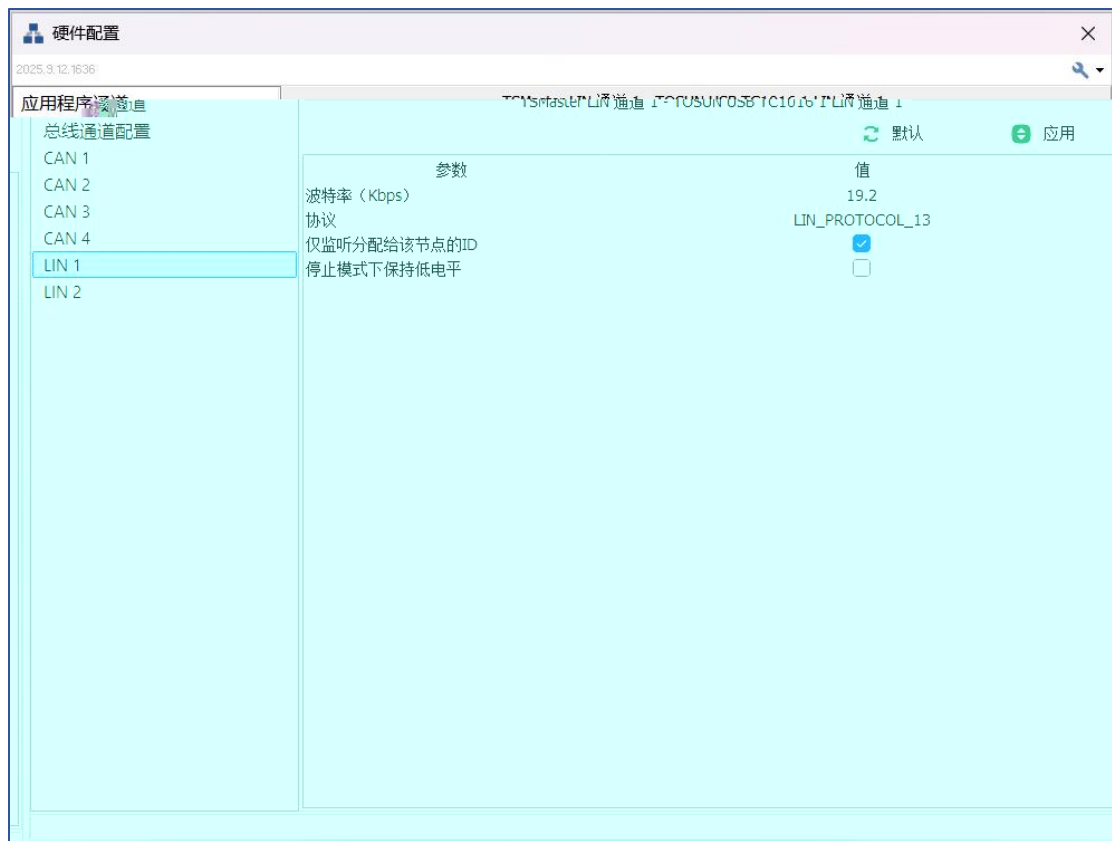

“

”

“

”

”

”

“

”

CAN / CAN FD 报文信息

绝对时间	计数	通道	标识符	帧率	报文名称	类型	DLC	数据长度	BRS	ESI	00	01	02	03	04	05	06	07	08	09	10
13.349605	1218	CAN 1	123	99		FD	Tx	8	1	0	00	00	00	00	00	00	00	00	00	00	00

列表计数: 1 总数量: 1218 0%

"

"

CAN统计数

绝对时间	13.349605
绝对时间 [100ms]	500
帧数 [帧]	1113
帧数 [帧]	1113
帧数 [帧]	1113
帧数 [帧]	99
帧数 [帧]	1113
帧数 [帧]	0
帧数 [帧]	0
帧数 [帧]	0
帧数 [帧]	0
帧数 [帧]	0
帧数 [帧]	0
帧数 [帧]	0
帧数 [帧]	0
帧数 [帧]	0
帧数 [帧]	1113
帧数 [帧]	99

C

"

"

"

"

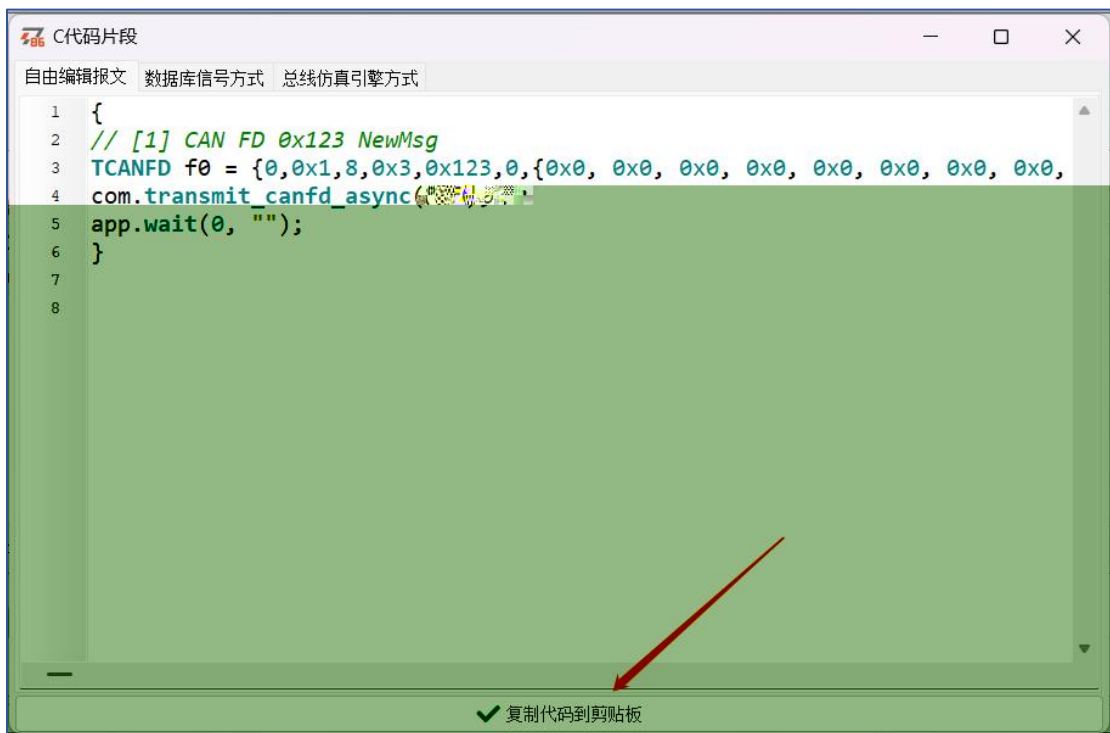
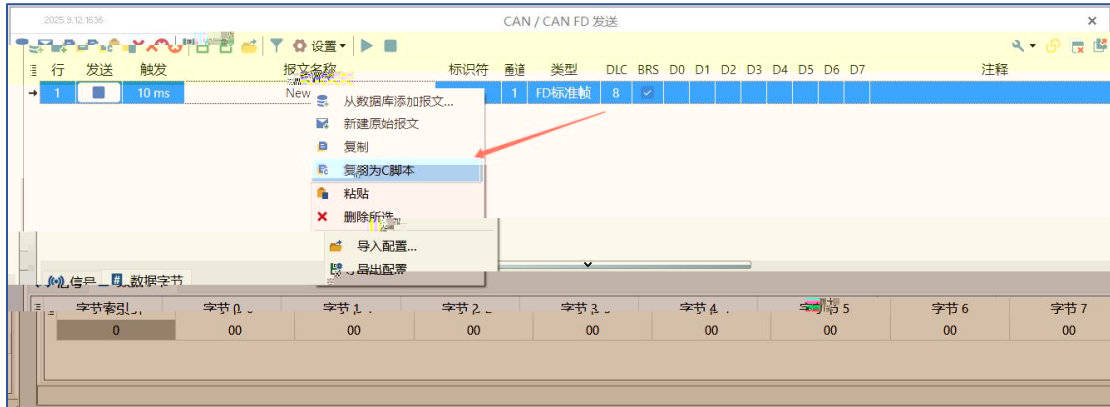

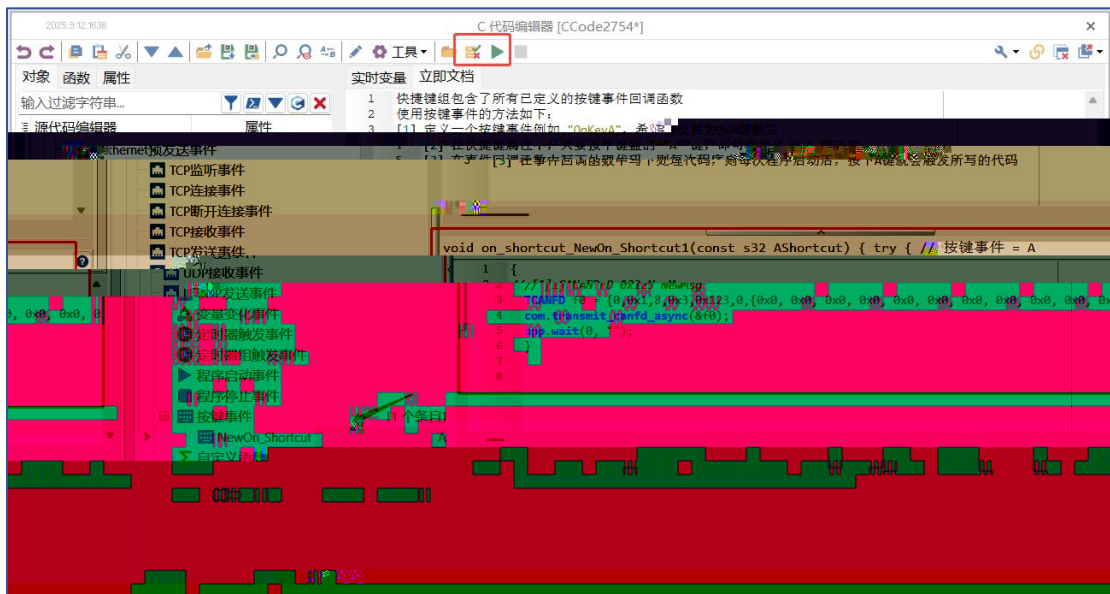
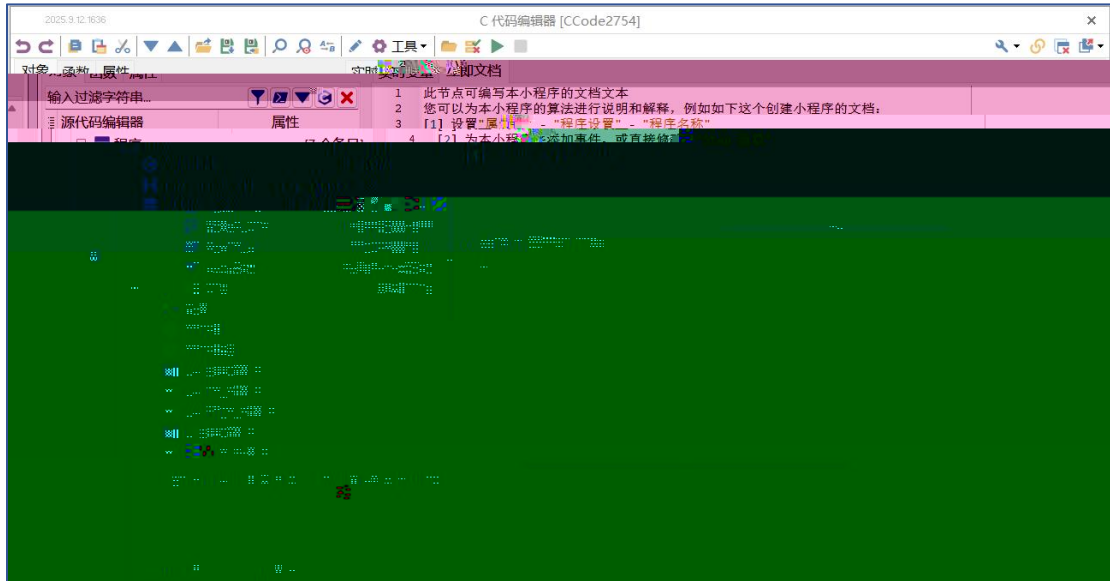

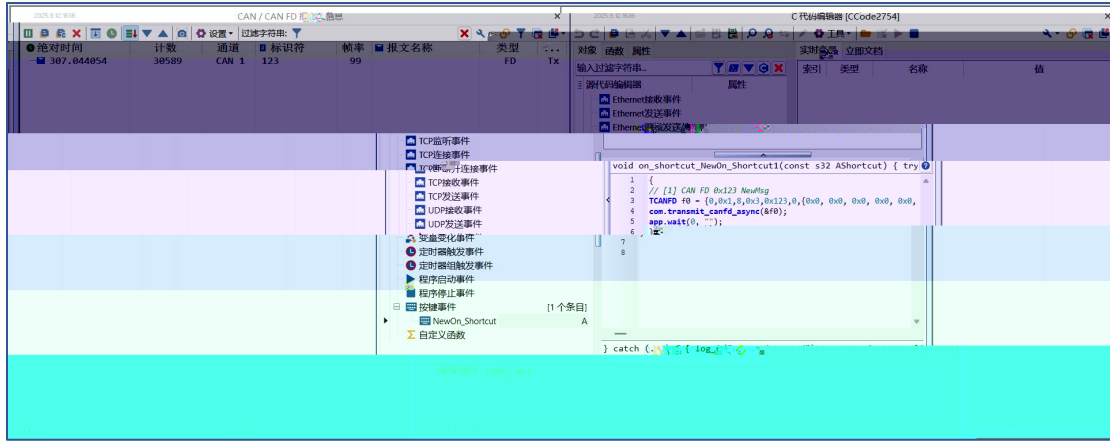

“ “ “ “



“ “

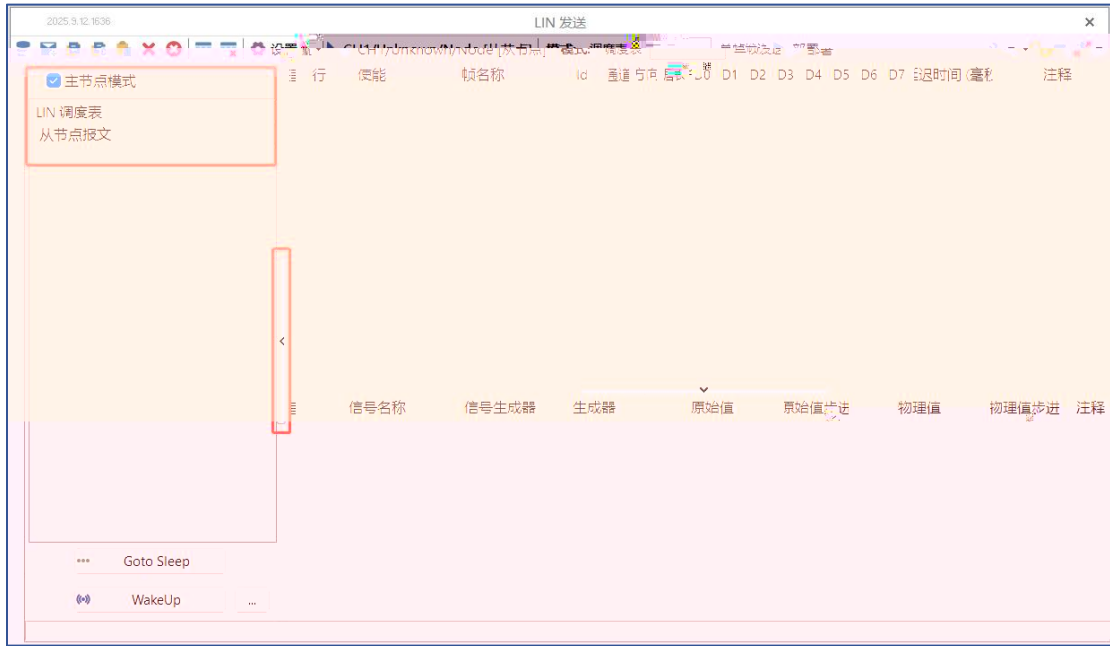

“ ”

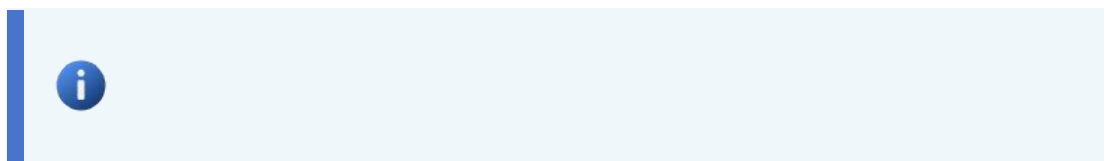
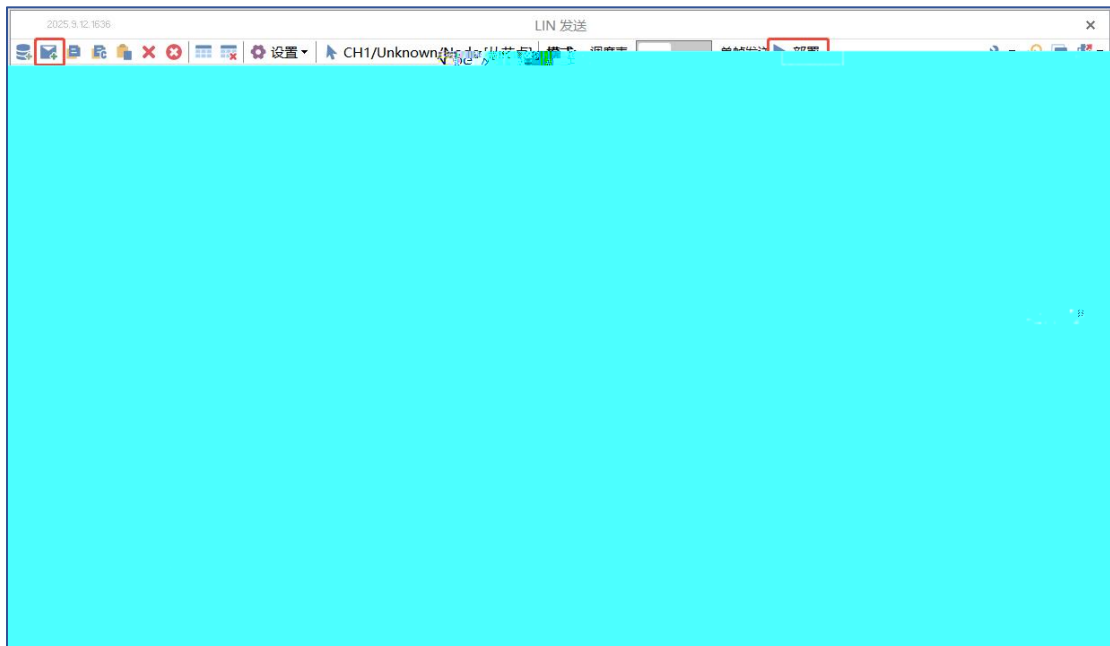

“ ” “ ” “ ” “ ”

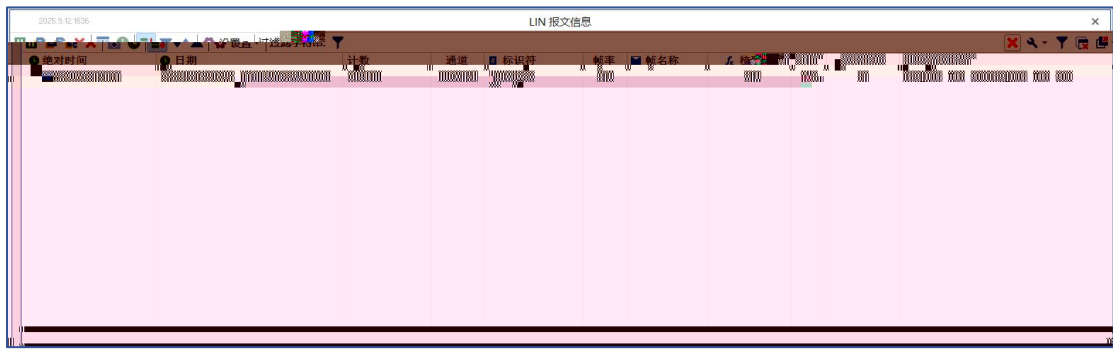

“ ”

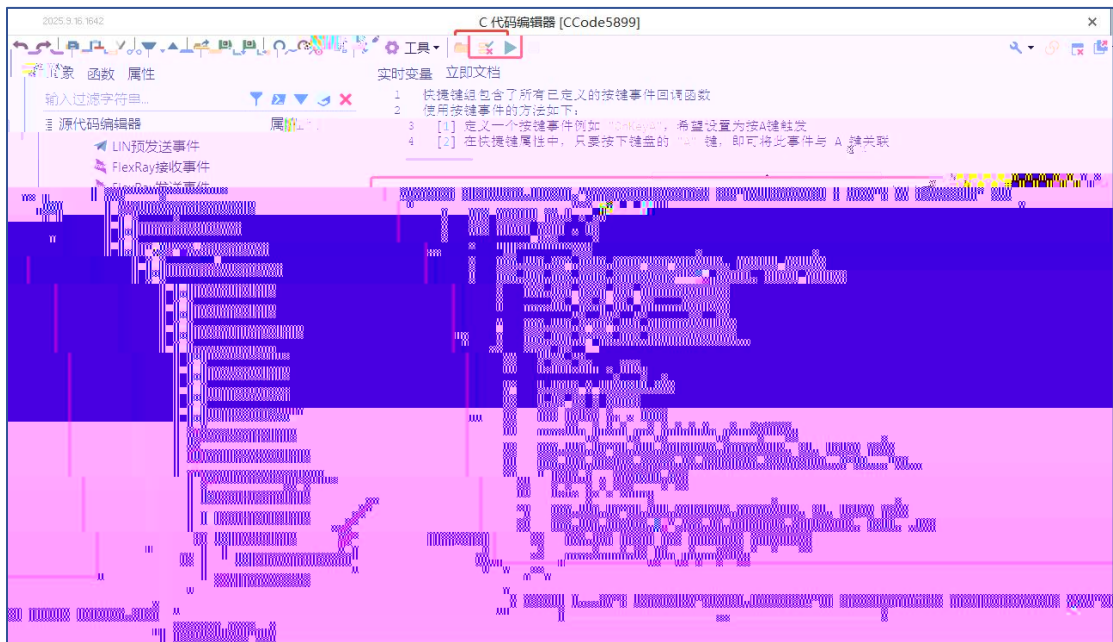

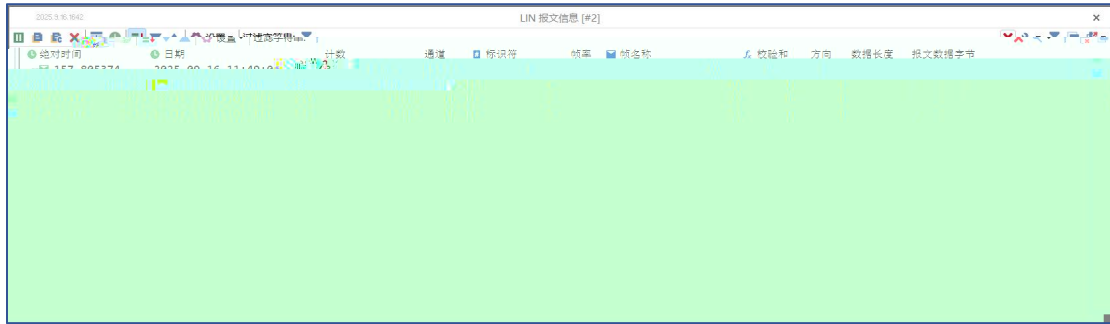

._ .e e

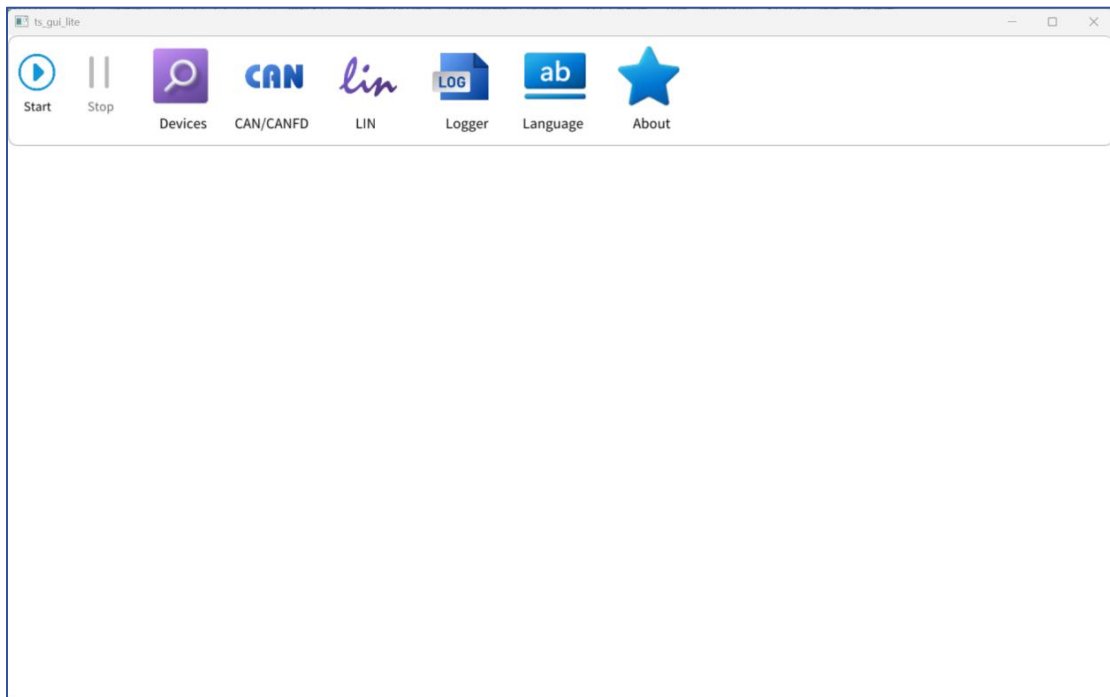

._ .e

“ ”

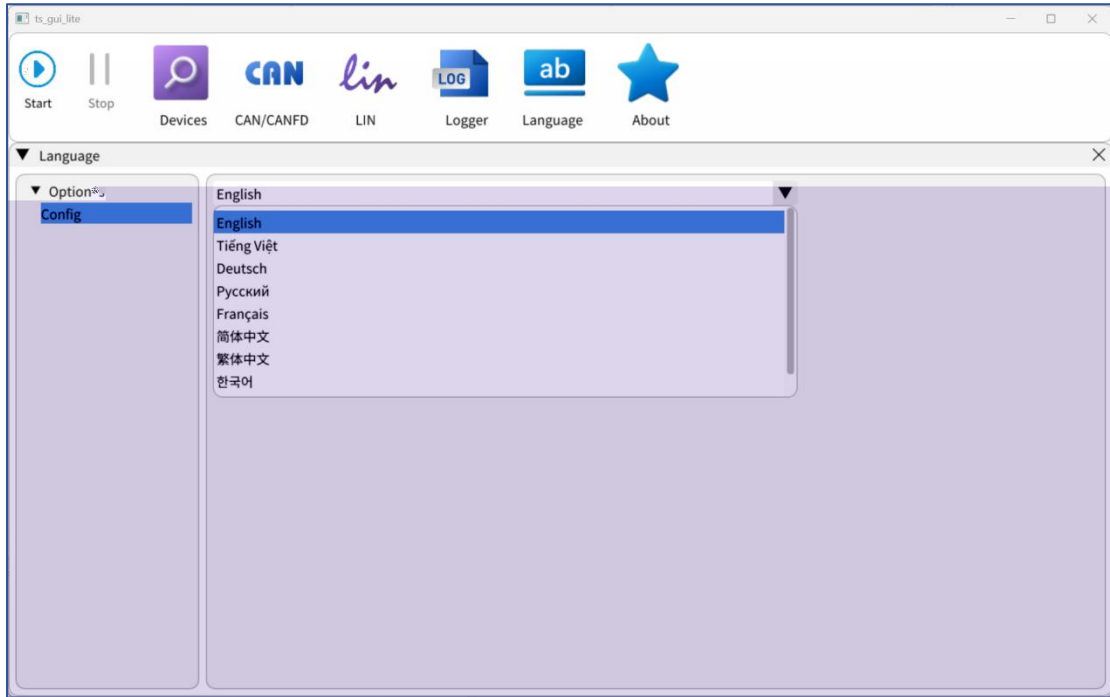

“ ”

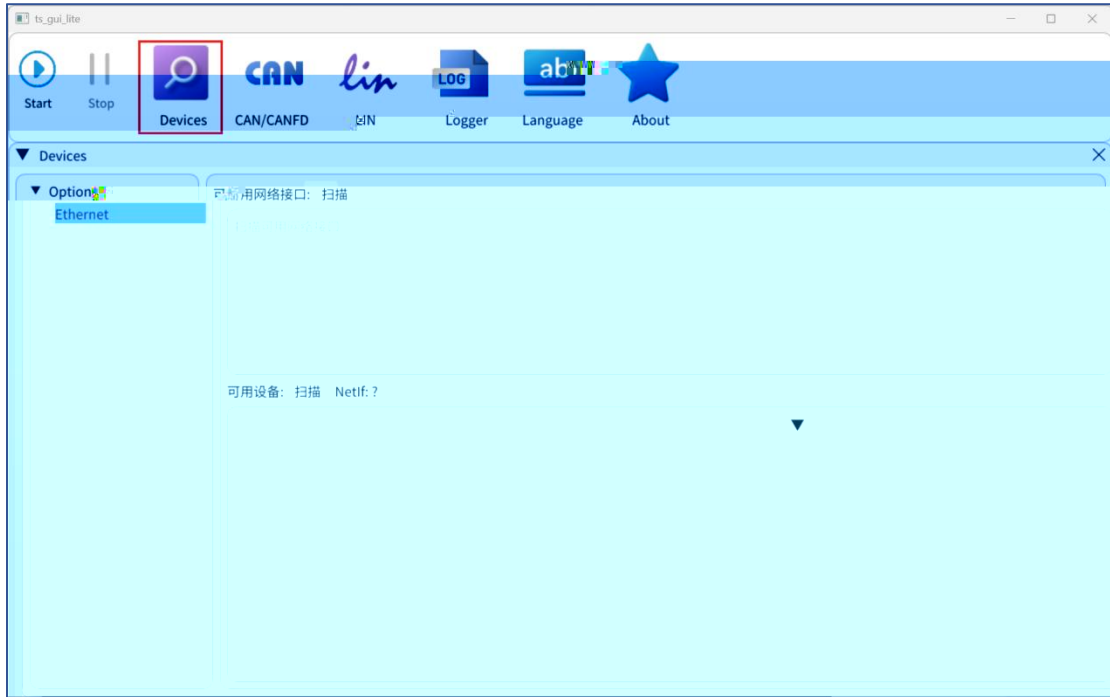

" "

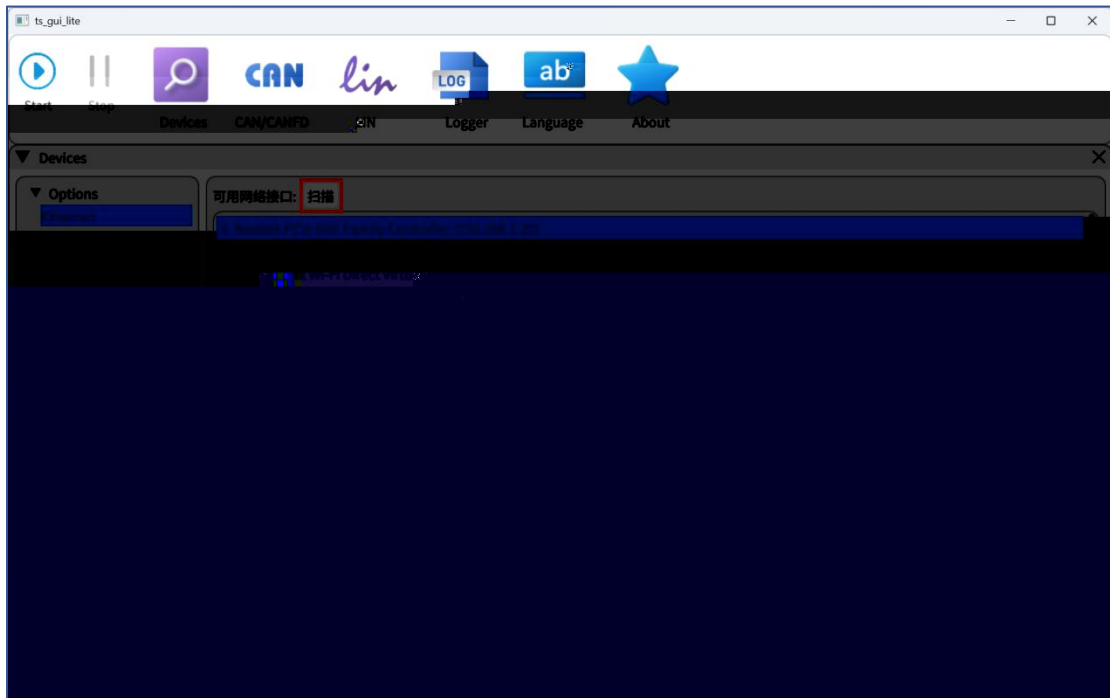

" "

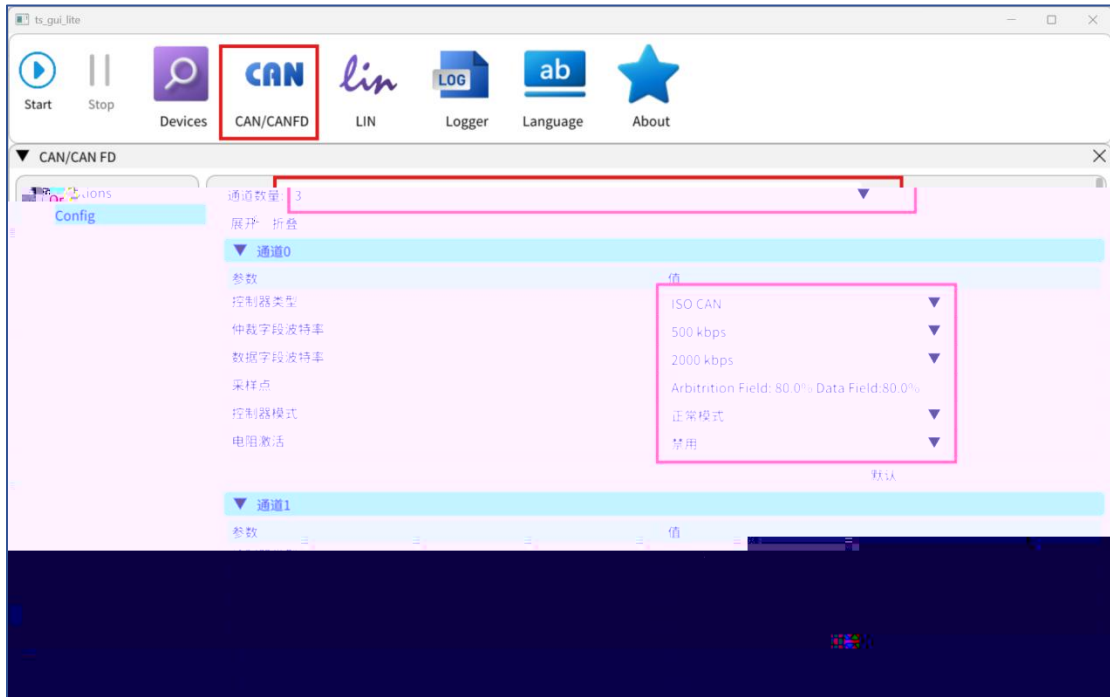

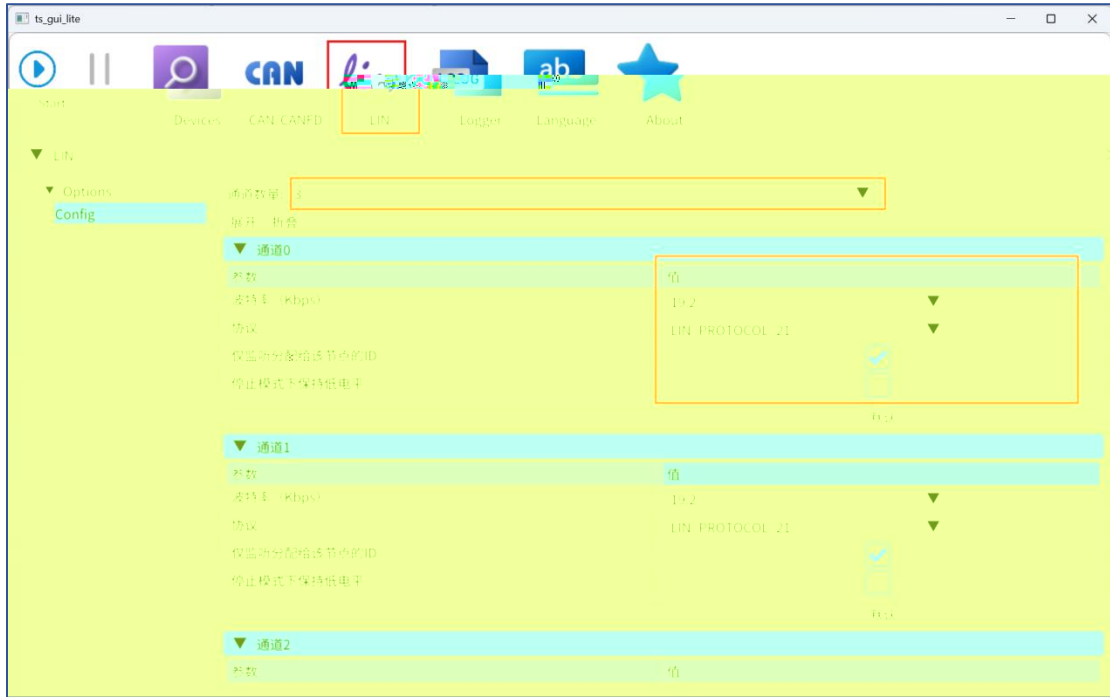

“ ”

“ ”

“ ”

“ ”

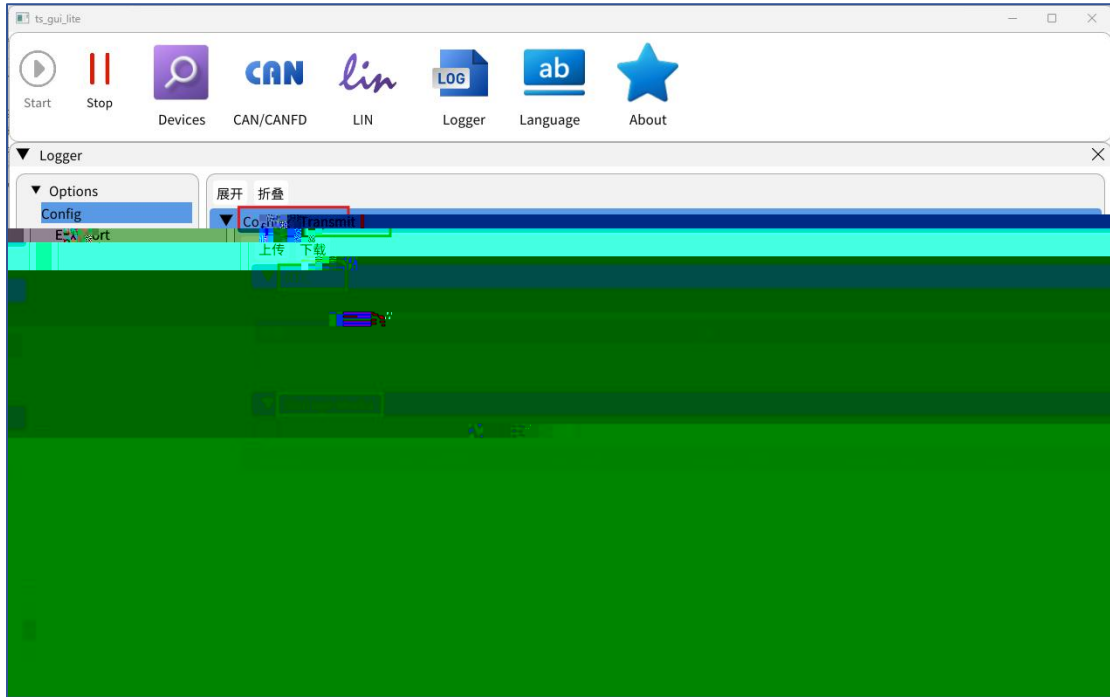

“ ”

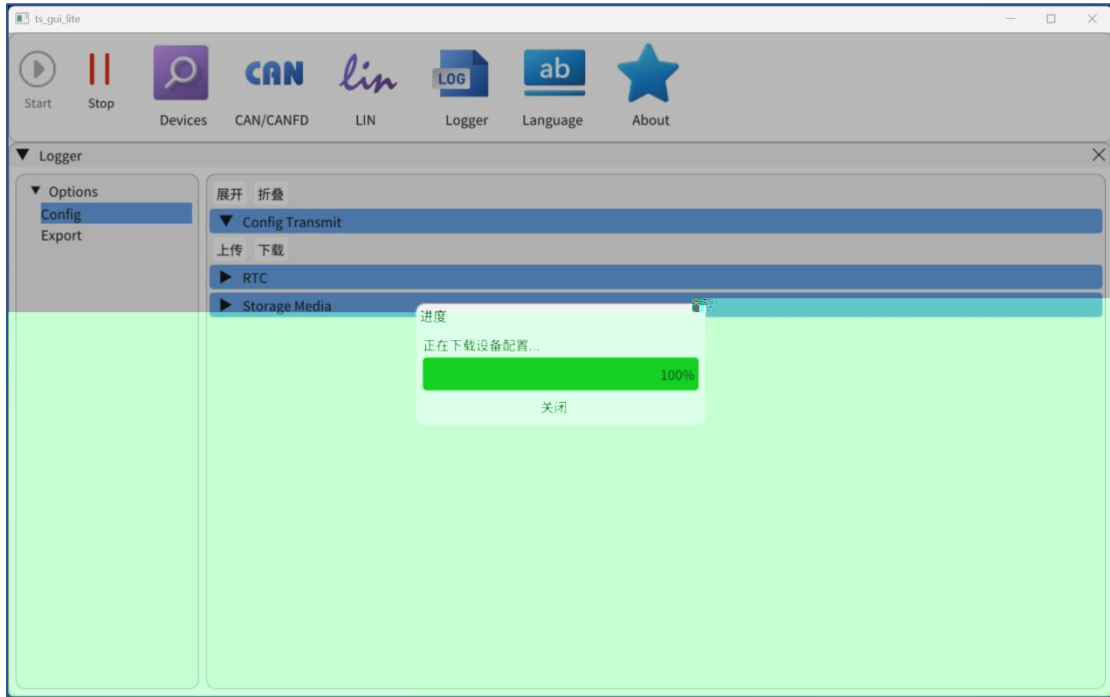

“ ”

“ ”

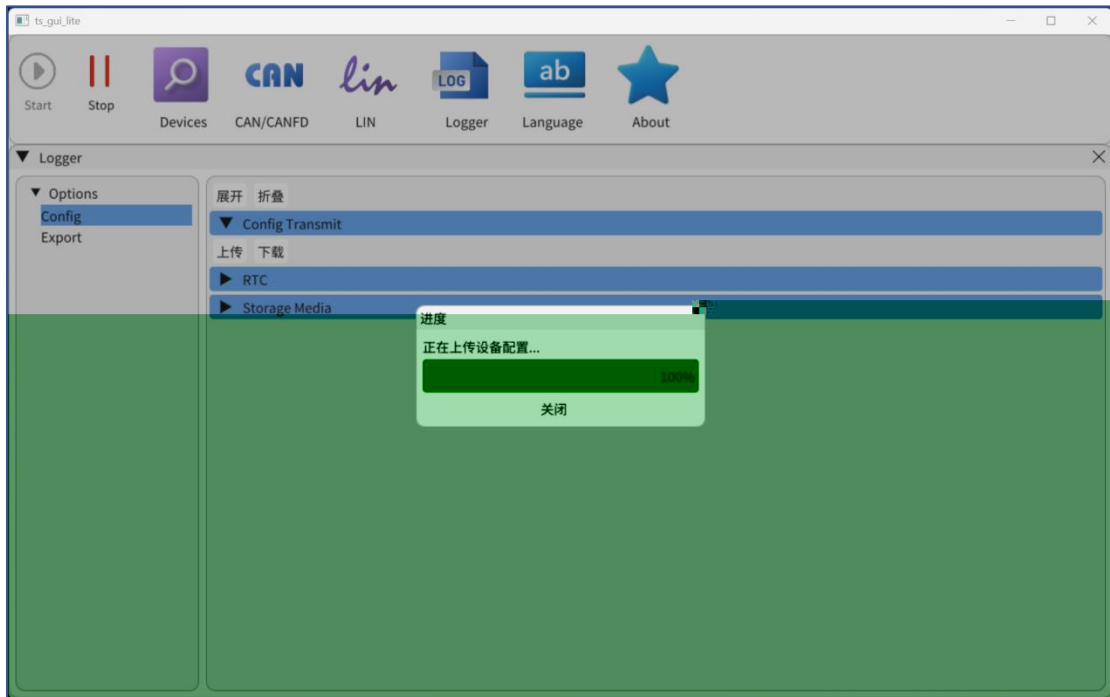

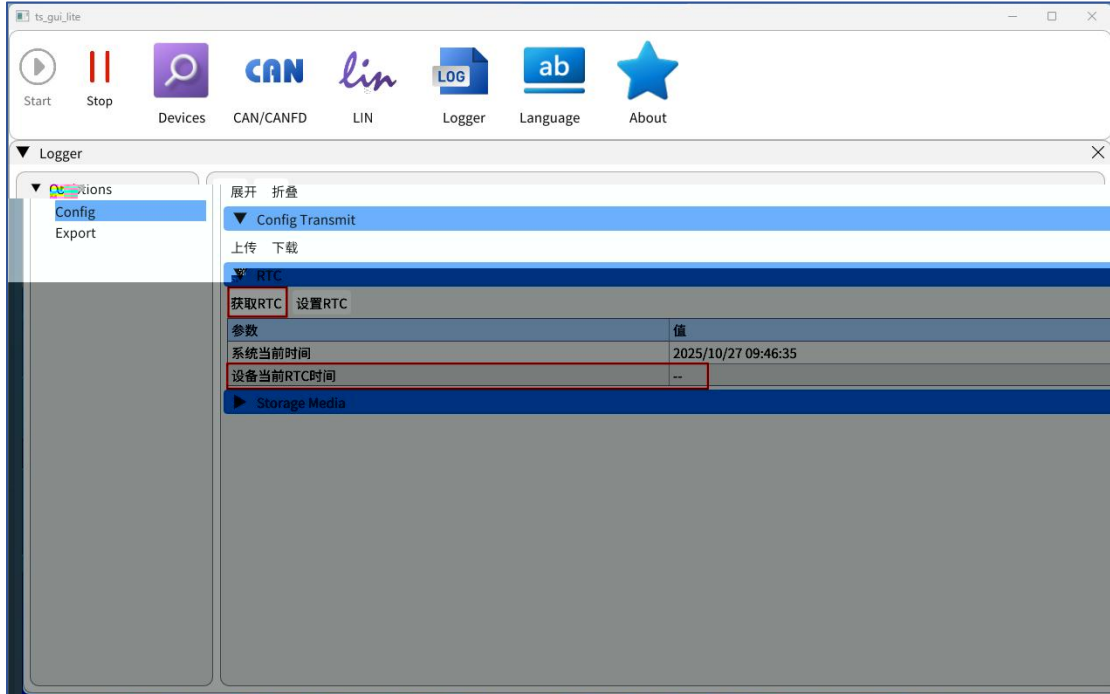

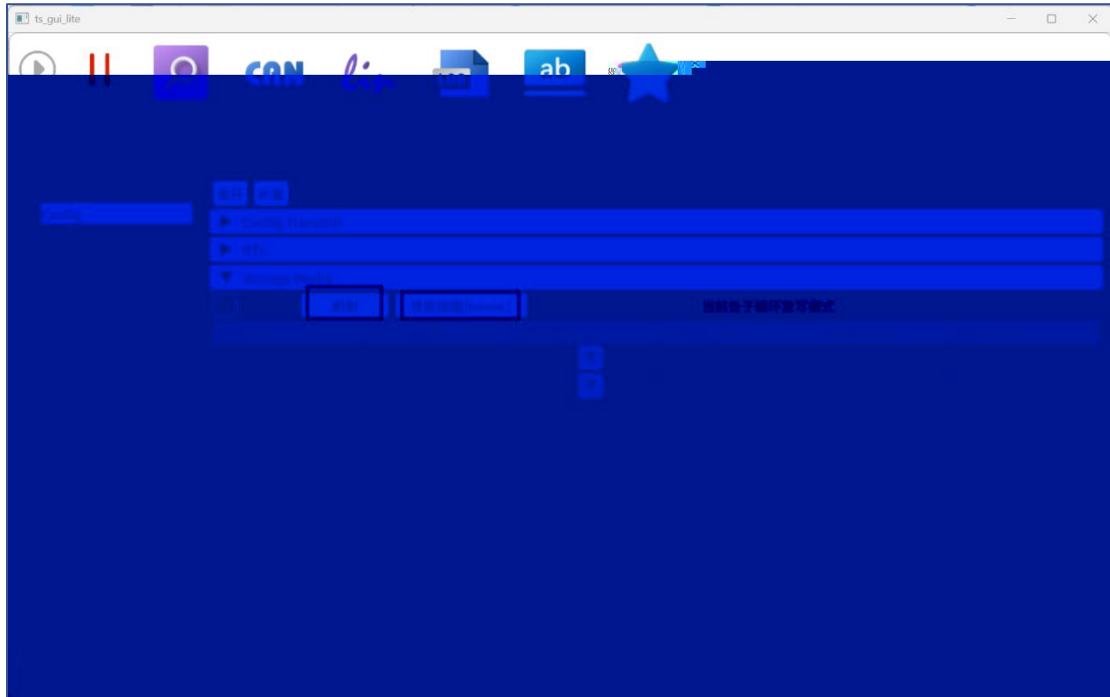

" "

" "

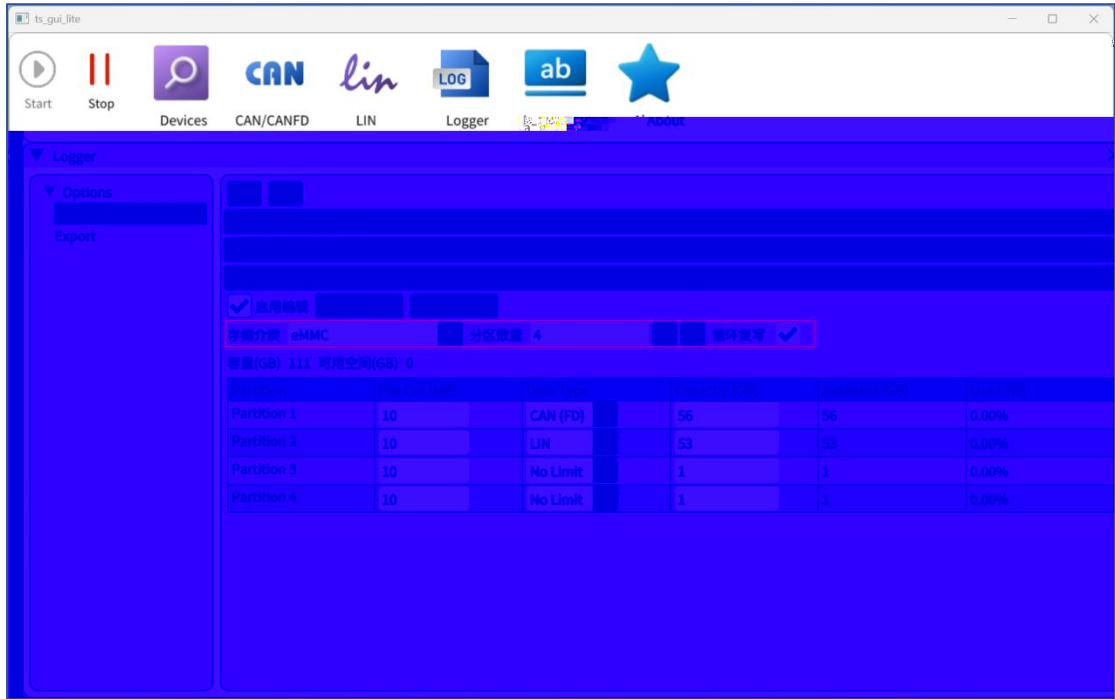

" "



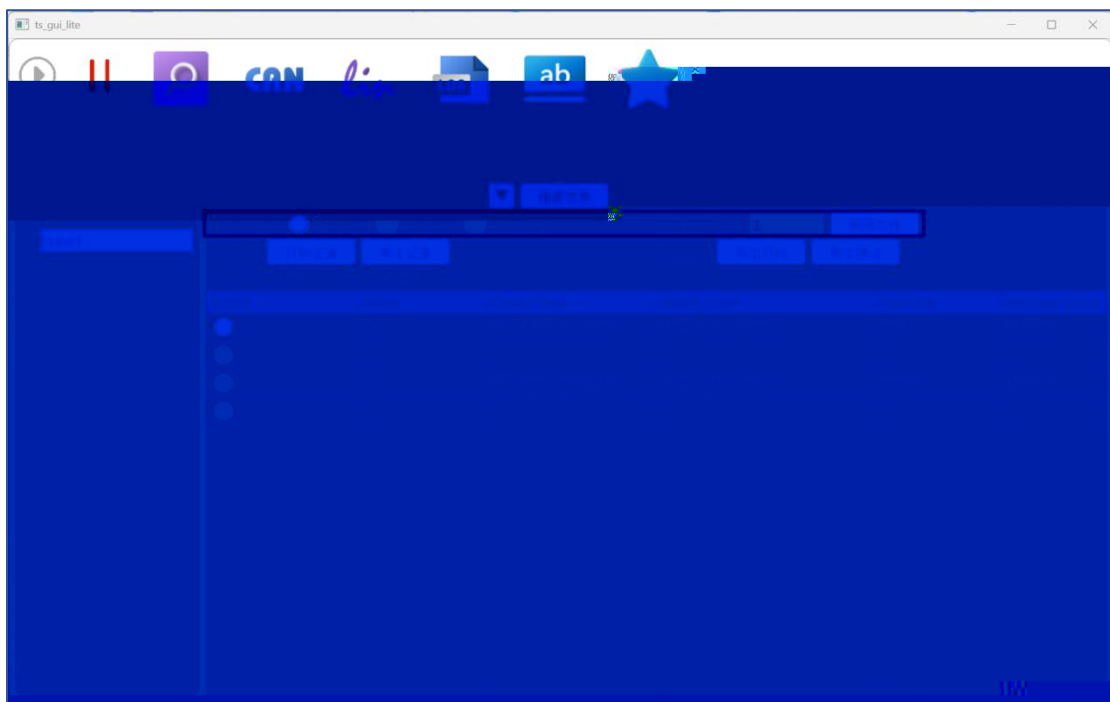

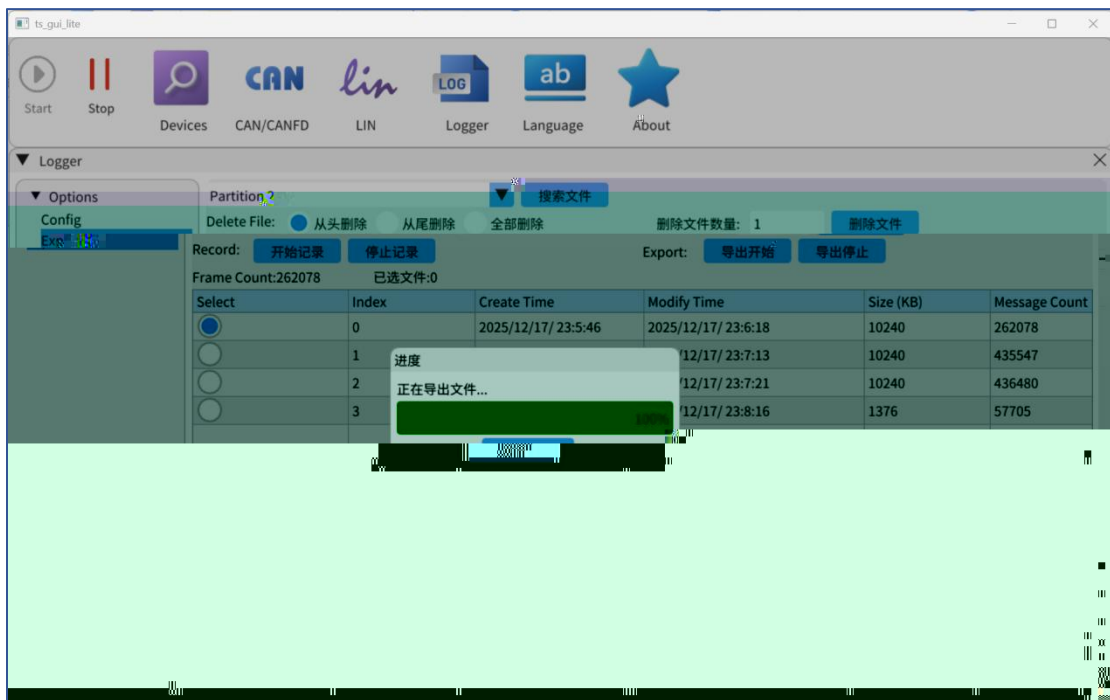

名称	修改日期	类型
Logger	2026/4/9 10:03	文件夹
imgui.ini	2026/4/27 11:28	配置设置
libLog.dll	2026/2/3 11:58	应用程序扩展
libTSDevBase.dll	2026/3/23 14:46	应用程序扩展
libusb-1.0_tosun.dll	2026/3/2 11:39	应用程序扩展
msvcp140.dll	2025/5/14 19:23	应用程序扩展
TLog1004.exe	2026/3/24 11:32	应用程序
tsdev_gui_src.dll	2026/3/11 11:04	应用程序扩展
vcruntime140.dll	2025/5/14 19:23	应用程序扩展
vcruntime140_1.dll	2025/5/14 19:23	应用程序扩展

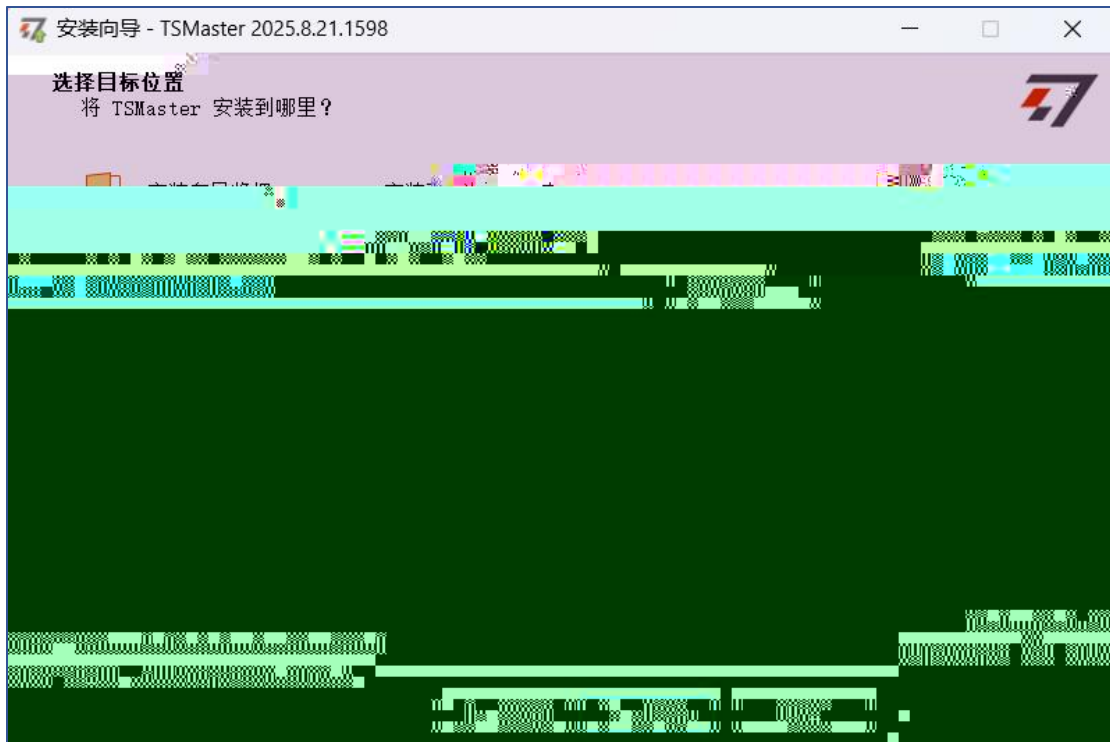
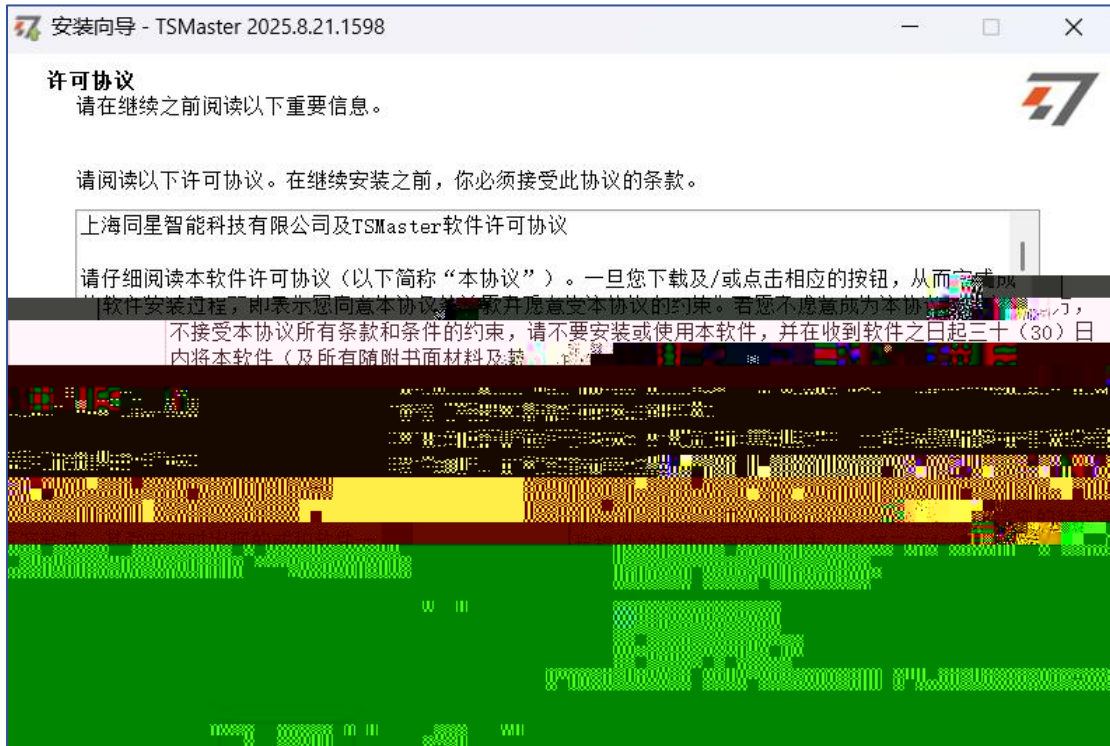

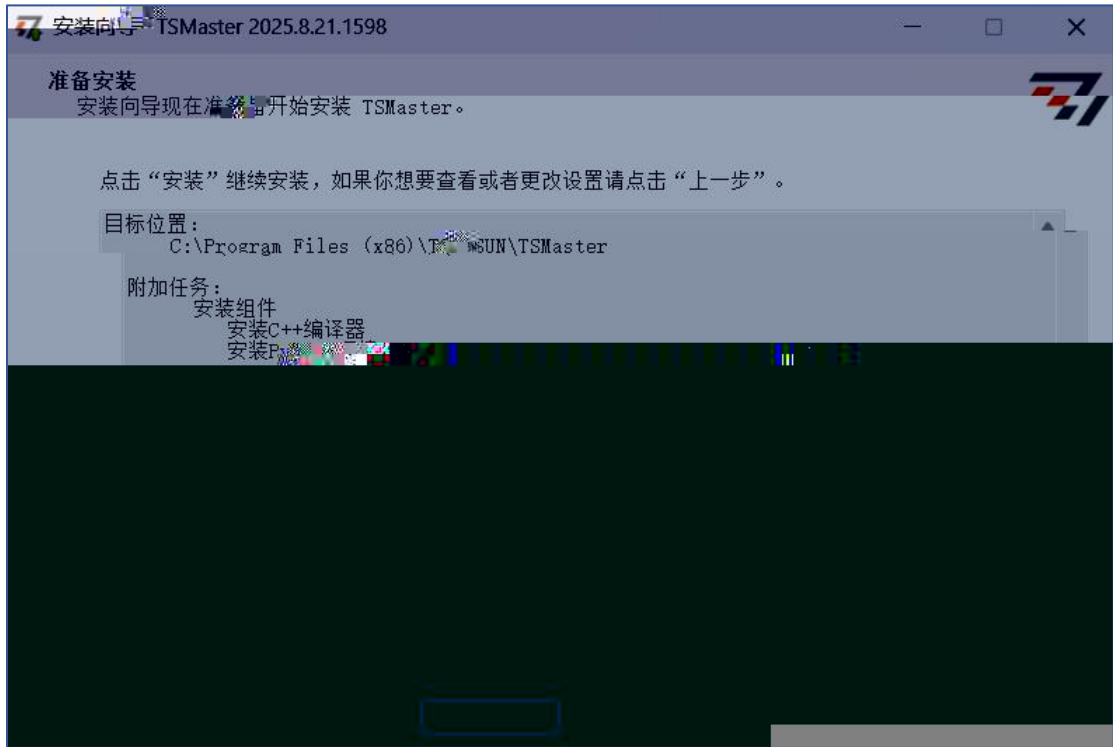
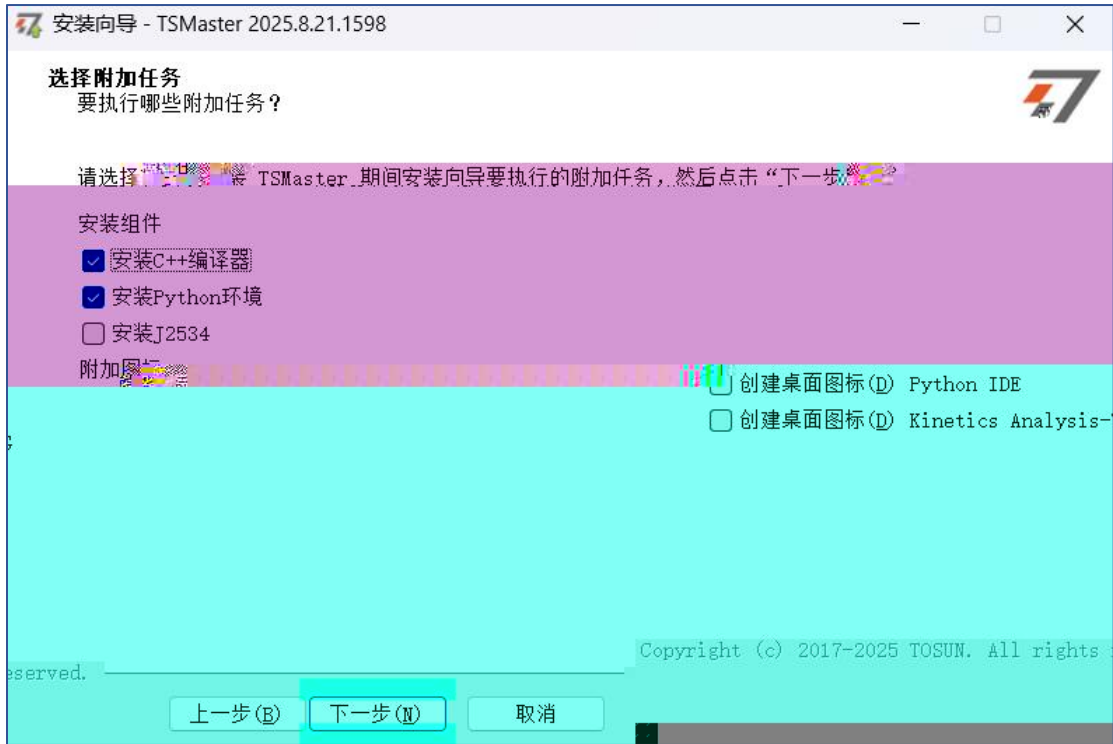

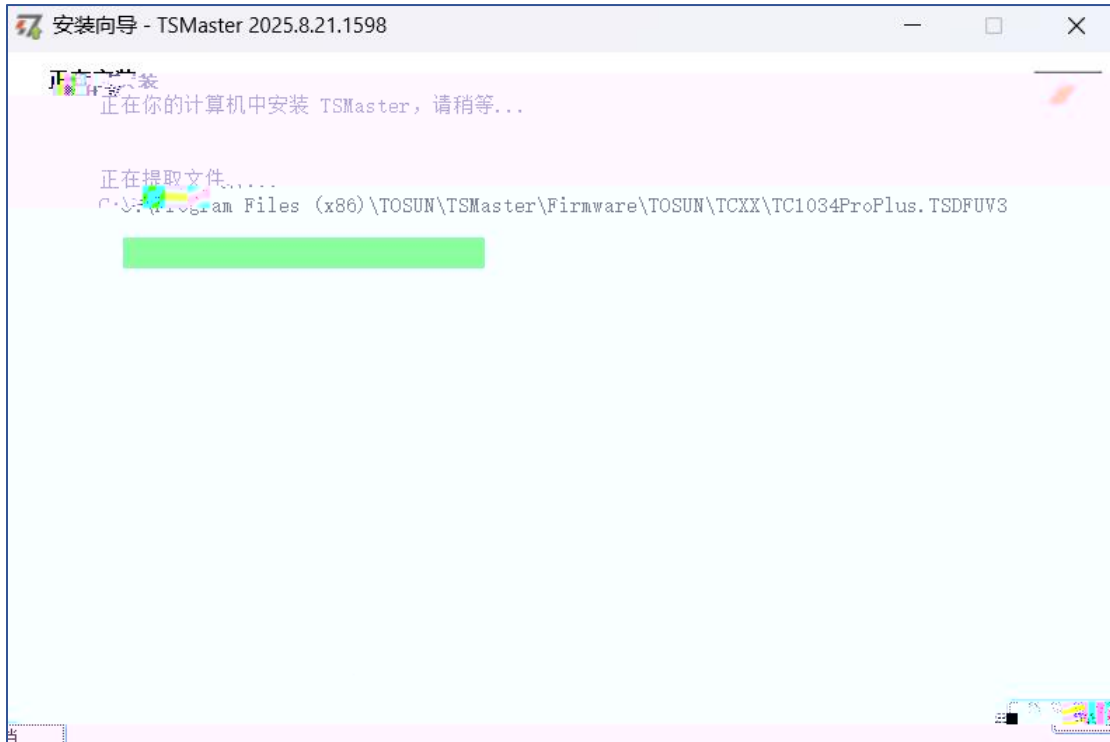

" "



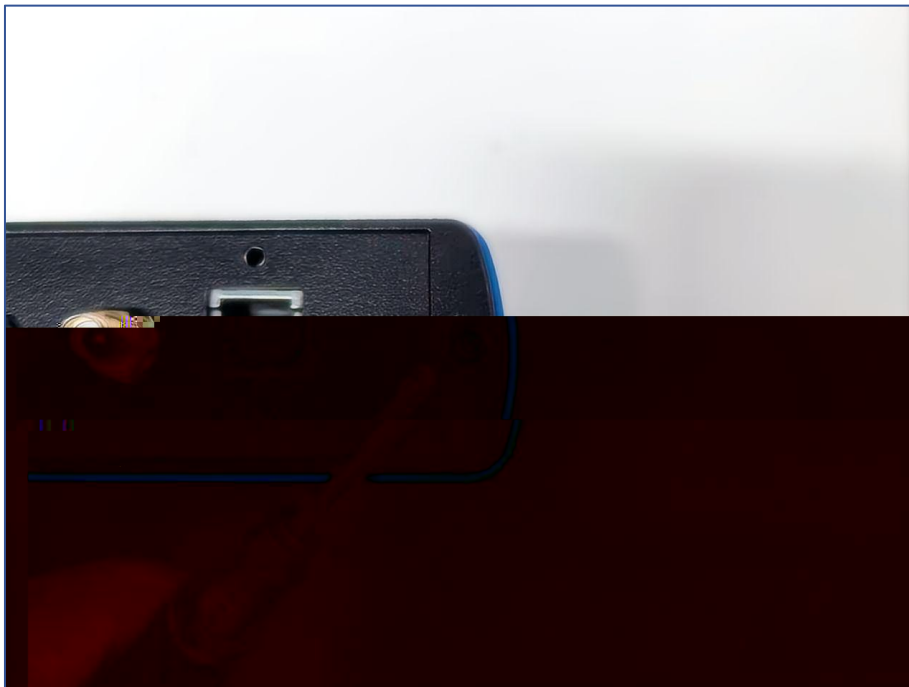
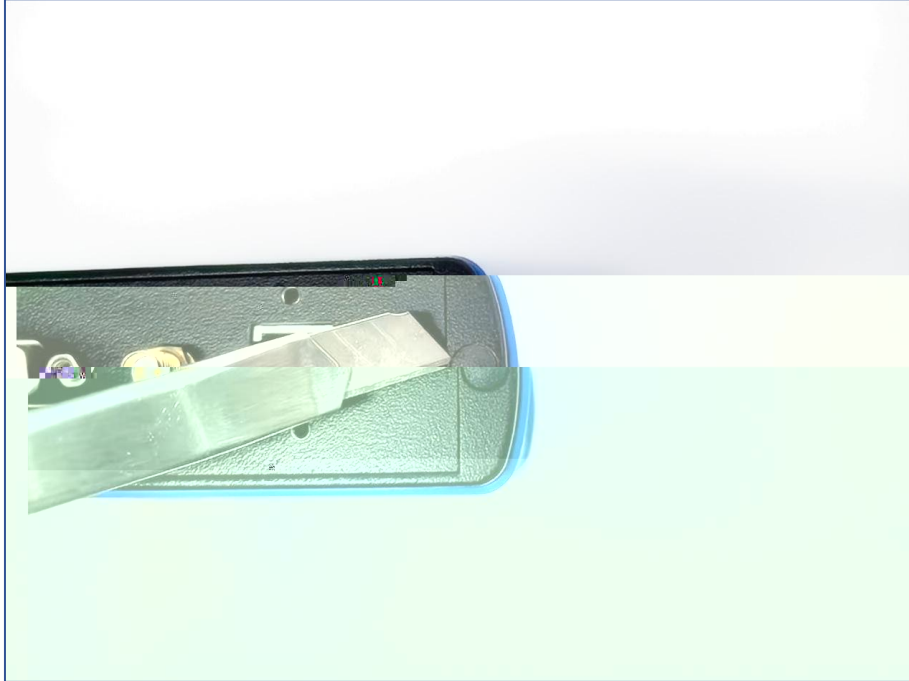

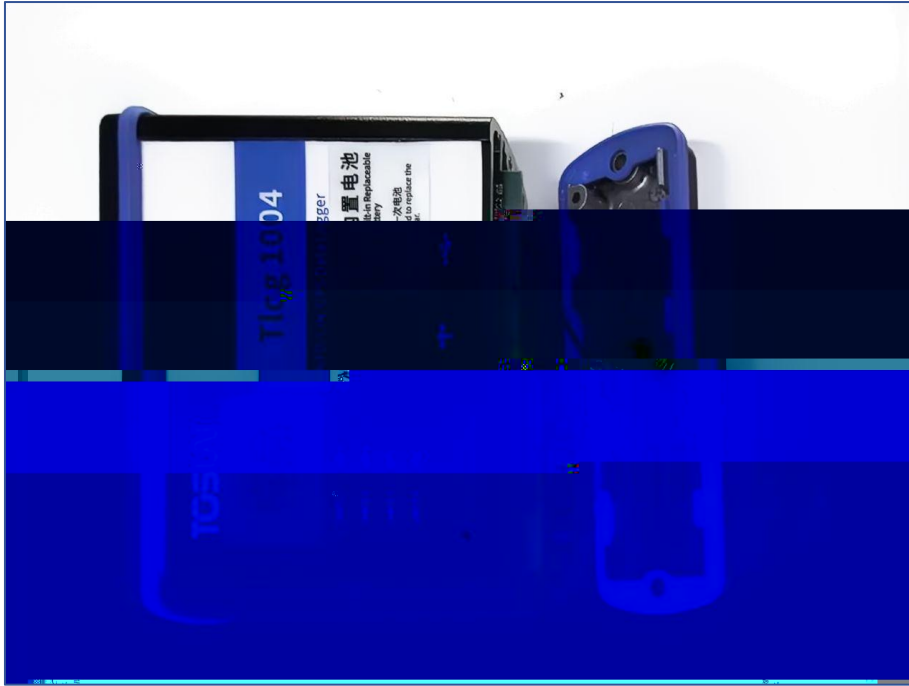

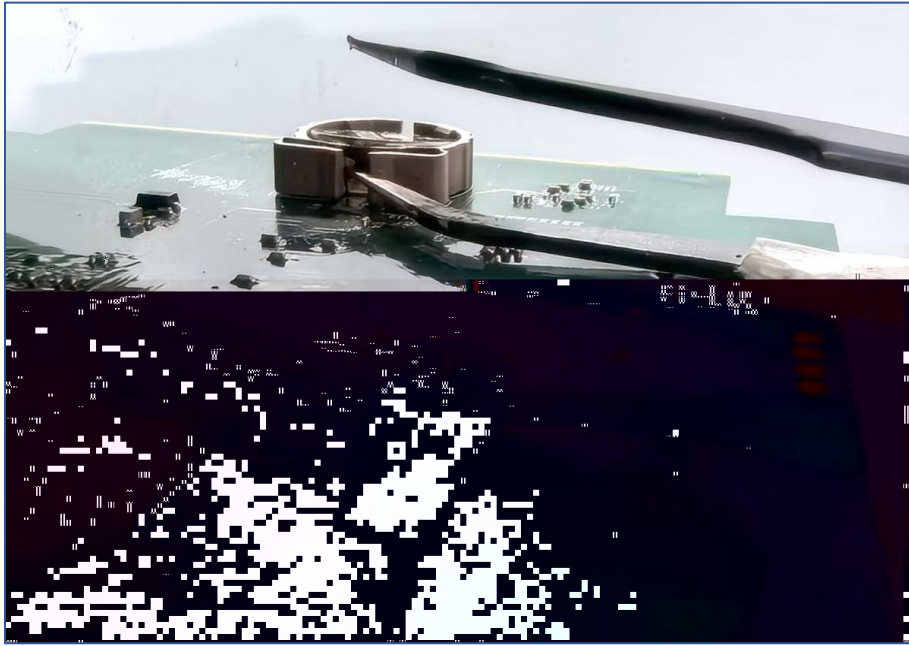

10000 1000 100 10 1

10000 1000 100 10 1

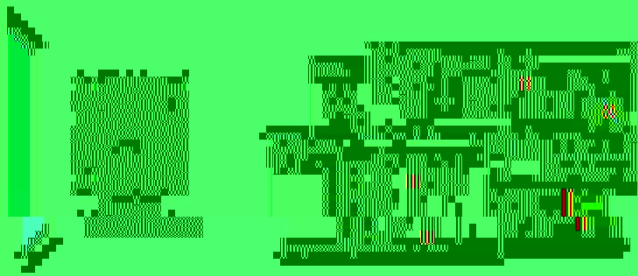

10000 1000 100 10 1

10000 1000 100 10 1



10000 1000 100 10 1

10000 1000 100 10 1

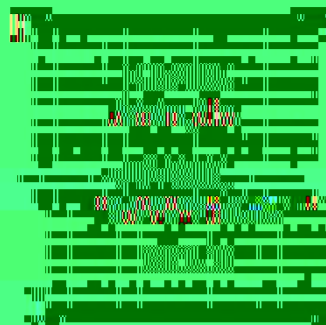

10000 1000 100 10 1



10000 1000 100 10 1

